

INDIAN INSTITUTE OF ASTROPHYSICS
IIND BLOCK, SARJAPUR ROAD, KORAMANGALA,
BANGALORE-560 034

PUBLIC TENDER NOTICE NO: PR/PT-UVIT-IIA/CAP/334 dt.Jan 28. 2008

1. The Director, Indian Institute of Astrophysics invites Bids from reputed firms for supply of the following item(s) . The firm(s) interested in offering bids should have executed similar works.

Sl.No.	Description In Brief	Quantity	E.M.D (refundable) Rs.	Tender Fee (non-refundable) Rs.
1.	Fabrication & supply of Leg assembly made out of stainless steel with leg pads as per the drawing and the technical specifications in Annexure II of this Tender.	8 Nos	20,000/-	250/-

Note: (1) The Tender documents with Technical details are available on IIA website www.iiap.res.in/tenders.htm. Hence the interested tenderers may at their option only download the same from our website and submit their offer along with EMD (refundable) & Tender fee (non-refundable) as prescribed therein, (only in the form of Demand Draft drawn in favour of Director, IIA. However, your offer (both Technical & Commercial bids) should be superscribed in separate envelopes mentioning the tender notice no., Date of opening and submit both the Bids in a sealed envelope addressed in favour of Director, IIA, Bangalore - 560 034.

2. The firms who fulfill the following requirements shall be eligible to apply.

- (a) Tendering Company shall be professionally managed and equipped with facility for fabrication and machining of large components, and should have the necessary inspection facility.
- (b) Tendering Company should have adequate shop floor space for assembly and testing.

- (c) Tenderer should have completed, in the last 3 financial years (i.e., current year and two previous financial years) atleast one similar work for a minimum value of of Rs.10 lacs.
- (d) The tenderer should submit Audited Balance Sheet duly certified by the Chartered Accountant to this effect. They should also submit Bankers Solvency Certificate to a minimum of Rs.10 lacs..
- (e) The Contractor will be required to produce the TDS Certificate indicating the Income Tax deducted by the client for similar works completed individually for the last 03 financial years of value not less than Rs.10 Lacs.
3. There may be a meeting before 14.02.2008 at IIAP, Koramangala, Bangalore-34 for technical discussions/clarifications if any, in relevant to the tender notice on our web site.i.e., before submitting Technical /Commercial / price Bids.
 4. The firms should submit both Technical and Commercial / price bids separately superscribed along with EMD amount **upto 1500 Hrs. Latest by 29 .02.08.** The Technical Bids will be opened in presence of the bidders or their representatives **at 1530 Hrs. on 29.02.2008.**
 5. Technical Bids supported by the above information should be submitted in Sealed envelope duly superscribed with the name of work. The completed Bids will be received **upto 1500 Hrs. on 29. 02.2008.**
 6. If any information furnished by the Vendor(s) is found incorrect at a later stage, the firm shall be liable to be debarred from tendering. The Institute reserves the right to verify the particulars furnished by the tenderers independently.
 7. Incomplete Technical Bids are liable for rejection. Commercial / price Bids will be considered only for the successful Technical Bidders.
 8. Late & / delayed offer will not be considered.

-2-

9. IIA is not responsible for any delay / loss of documents in transit.
10. The Commercial / price Bids will be opened on **10.03.2008 at 1530 Hrs.**

of those firms technically qualified, in the presence of bidders or their authorised representatives.

11. IIA reserves the right to reject any tenders without assigning any reason and to restrict the list of Technically qualified & recommended firms to any number deemed suitable.

Administrative Officer
IIA, Bangalore-34.

-3-

Annexure-I

IMPORTANT: TWO PART TENDER INSTRUCTIONS

1. It is proposed to have a two cover system for this tender.

Part I: (a) Technical and (b) commercial part (without price) is one cover.

Part II: Price part alone is another cover.

2. **TECHNICAL PART :**

Technical part should clearly indicate the technical details. A compliance statement indicating whether the specifications are met is to be submitted with reasons for deviations if any. Complete with Drawings, in relevant to the offer are also to be enclosed to the technical part.

3. **COMMERCIAL PART (without price)**

Commercial part should indicate commercial terms like, delivery period, place of delivery, payment terms, validity, warranty/guarantee etc. and should be sent along with the technical part. Both technical and commercial part shall not contain price details. The Technical and Commercial part should be kept in one cover along with tender Fees superscribing tender number and due date and should be sealed.

4. **PRICE PART** alone should be kept in a separate cover superscribing the tender number and due date.

5. Both the technical and commercial part (with tender fee wherever applicable) in one cover and **price part** in another cover should be put in one large cover and the cover should be super scribed with the tender number, due date and time of opening.

5. The Sealed covers should be sent to the following address:-

THE DIRECTOR, INDIAN INSTITUTE OF ASTROPHYSICS., II ND
BLOCK, KORAMANGALA, BANGALORE – 560 034.

6. The offer should be valid for a minimum period of 120 days from the due Date.

7. Offer shall be submitted in sealed covers only.

8. No conditional discounts will be allowed.

-4-

9. Tender fee of requisite value shall be sent along with the tenders by demand draft drawn in favour of “The Director, Indian Institute of Astrophysics., Bangalore” drawn from any Indian Nationalised Banks/Reputed Banks in India..

10. The interested tenders may refer to Tender notice also released in the leading News Papers for the convenient to down load the Tender documents from the IIA website www.iiap.res.in/tenders.htm.
11. Tender shall be submitted as above without fail.

Phone: 25530672-676
Fax : 25534043
E-mail: Astron@iiap.res.in

INDIAN INSTITUTE OF ASTROPHYSICS
IInd Block, Koramangala, Bangalore-560 034

No.PR/PT-UVIT-IIA/CAP/334

Dt: .01 .2008

M/s.

Dear Sirs,

The Director, Indian Institute of Astrophysics, Bangalore invites Sealed Tenders for the supply of Stores detailed in the Tender Form hereto annexed. The Tender Terms are also enclosed may be noted carefully. If you are in a position to quote for the supply in accordance with the requirement, please submit your quotation in the attached Tender Form.

Your Tender (both Technical & Commercial / price Bids) must reach this office on or before the date and time indicated in the Tender Schedule.

Thanking you,

Yours faithfully,

(AJ Raghupathy)
Admn. Officer
For Director

Encl: as above.

INDIAN INSTITUTE OF ASTROPHYSICS
BANGALORE-560 034

PUBLIC TENDER DOCUMENT NO:PR/PT-UVIT-IIA/CAP/334
DT: 28 JANUARY 2008

TENDER FORM

FROM:

TO

THE DIRECTOR,
Indian Institute of Astrophysics.,
Bangalore-560 034.

Sir,

I/We hereby offer to supply the stores indicated below at the price hereunder quoted and agree to hold this offer open till_____. I/We shall be bound to supply the store hereby offered upon the issue of the Purchase Order communicating to the acceptance thereof on or before the expiry of the last mentioned date. You are at liberty to accept any one or more of the items of such stores. I/We not withstanding that the offer in this tender has not been accepted in whole, shall be bound to supply such items and such portion or portions of one or more of the items as may be specified in the said Purchase Order communicating the acceptance.

Sl.No.	Description of the item(s)	Quantity	Unit	Rate	Dely. Period
1.	Fabrication & supply of Leg assembly made out of stainless Steel (SS304L) with leg pads as per Drawing and the technical specification in Annexure II of this Tender.	8	Nos		

Place at which the Delivery is required : To MGKM Lab. CREST near
Hoskote, Karnataka

Date by which the supplies are required : 2 months FDO.

2. I/We have understood the items of the tender annexed to the invitation to the Tender and have thoroughly examined the specifications/drawing and /or pattern quoted or referred to herein and/are fully aware of the nature of the stores required and my/our offer is to supply the stores strictly in accordance with the requirements subject to the terms and conditions contained in the Purchase Order communicating the acceptance of this tender either in whole or in part.

Date:

Signature and seal of Tenderer

ANNEXURE II- TO PUBLIC TENDER NO.PR/PT-UVIT-IIA/CAP/334
Dated 28th Jan 2008

1.0 Introduction

A vacuum chamber of length 4500mm and diameter of 1000mm has been installed at MGK Manon's Laboratory, Indian Institute of Astrophysics, CREST, Hosakotte. The total weight of the chamber is about 4000Kg. There are eight leg pads welded to the chamber which are meant for placing the chamber over the leg assembly.

The leg assembly consists of two C channels welded together to form a square tube. The ends of the tube is machined to the required accuracy and welded with two plates of thickness 23mm. The total height of the leg assembly is 550mm after machining of the end plates. The parallelism between the end plates should be better 100micron and perpendicularity of the plates to the tube should be better than 200 micron. The material of construction is SS 304L. More details on dimensions and tolerances, refer the enclosed Drawings.

1.1 Scope of the work

Scope work is fabrication of leg assemblies as per the enclosed drawing, delivery, installation in our laboratory.

1.2 Leg Assembly Specification

- Material Constructions : Stainless steel of grade AISI 304 L (ASTM standard of grade SA-240-TP-304L)
- Size and shape: As per the enclosed drawing
- Welding: The root pass weld shall be TIG Argon arc welding Following ASME code sec. IX. The subsequent welding passes shall be done using suitable stainless steel electrode and manual arc welding. All inside welds are to be continuous and outside surfaces can be staggered.
- Surface Finish:
Outside surfaces: All the legs outside surfaces shall be buffed smooth to mirror finish.
- Weld joint finish: All weld joint should be sand blasted

2.0 Dimensional Inspection:

- The complete dimensional check has to be carried out by Vendor/Supplier which will be witnessed by our Engineers at vendor's site prior to delivery

2.1 Installation

- Leg assembly is to be installed in the Prof. M. G. K. Menon Laboratory of IIA, CREST, Hoskote

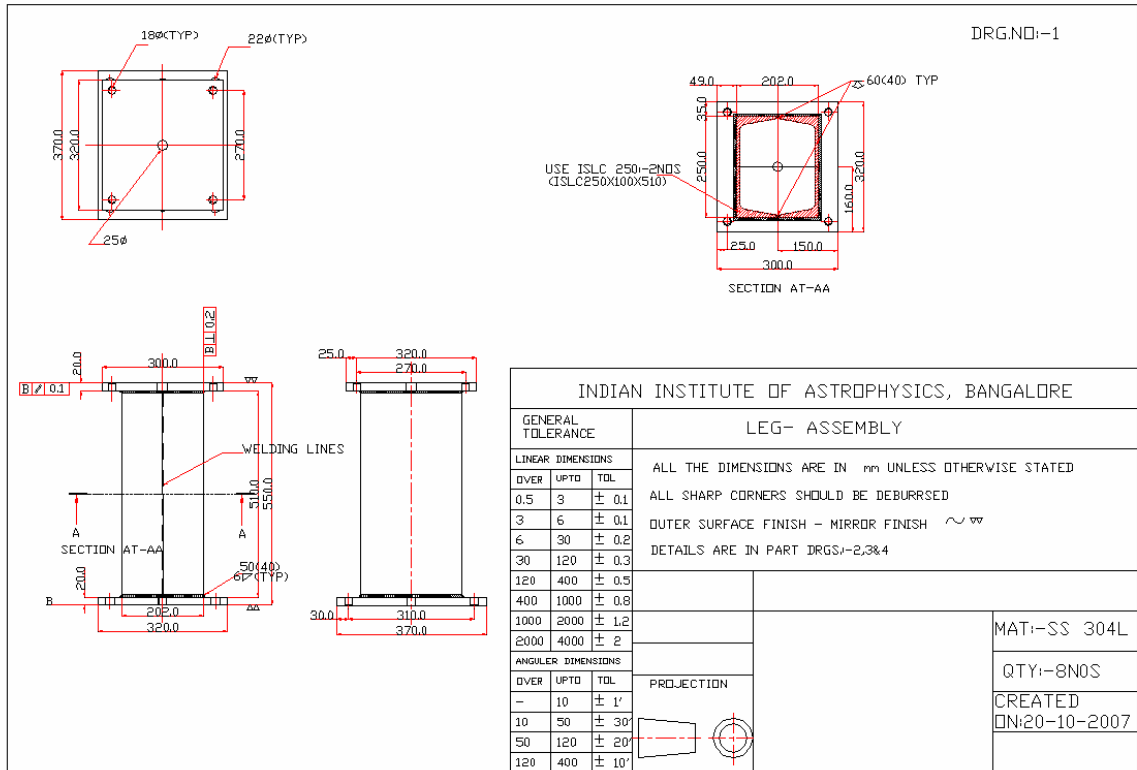

Drawings

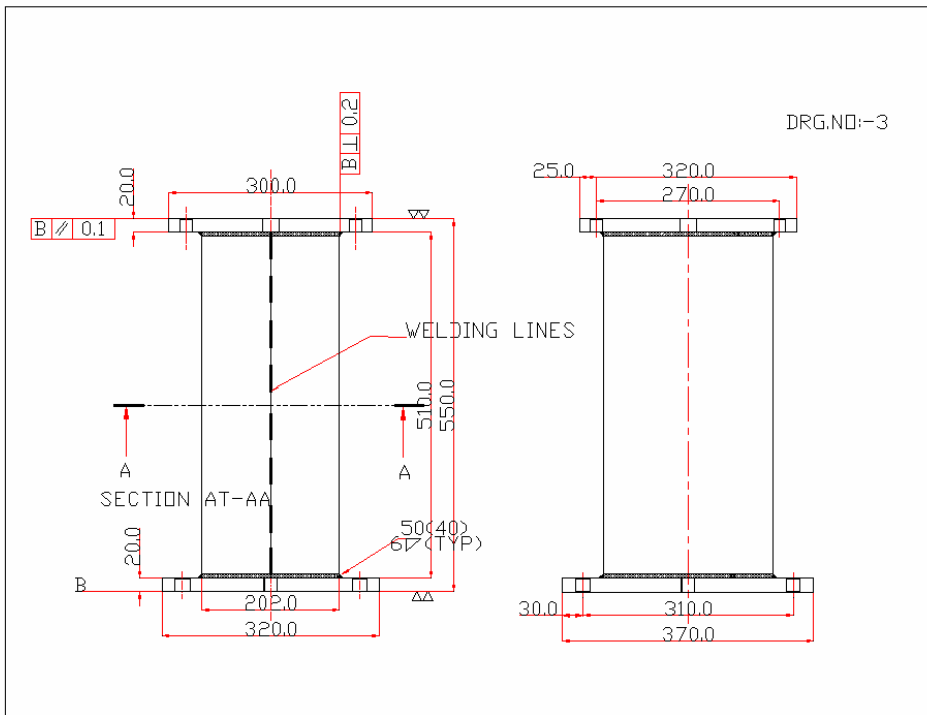
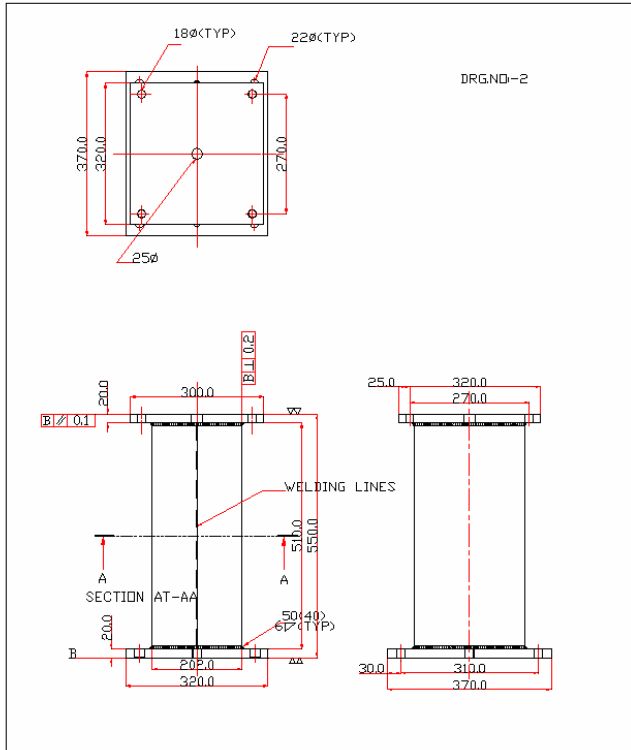

DRG.NO:-4

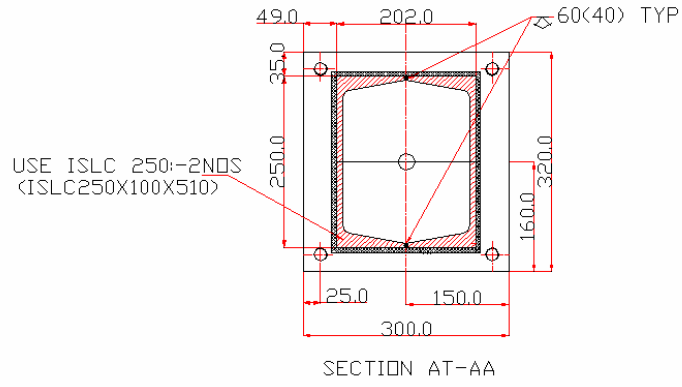

Annexure - III
INSTRUCTIONS TO TENDERERS

1. Tenders should be sent in sealed and superscribed envelopes with mention of Tender No. date and date of opening. Only one Tender should be sent in each envelope.
 2. Late and Delayed Tender will not considered at all.
 3. Duties, Taxes where legally leviable and intended to be claimed should be distinctly shown separately in the Tender.
 4. As a Govt. of India Department, this office is exempted from the payment of Octroi Duty and similar local levies (but not providing any C or D forms) Tenderers shall ensure that necessary exemption certificates are obtained from the officer concerned to avoid any payment of such levies.
1. a) Your quotation should be valid for 120 days from the date. of opening of tender.
b) Prices are required to be quoted accordingly to the units indicated in the annexed tender form. When quotations are given in terms of units other than those specified in the tender form, relationship between the two sets of units must be furnished.
 2. Preference will be given to those tenders offering supplies from ready stocks and on the basis of F.O.R Destination/Free door delivery at Site.
 3. a) All available Technical Literature(s), Catalogue(s) and other data in support of the specifications and details of the item(s) should be furnished along with the offer.
b) Samples, if any, called for, should be submitted free of all charges by the tenderer and the Purchaser shall not be responsible for any loss or damage thereof due to any reason whatsoever. In the event of non-acceptance of tender, the tenderer shall have to remove the samples at his own expense.

c) Approximate net and gross weight of the items offered shall be indicated in your offer. If dimensional details are available the same should indicated in your offer.

d) SPECIFICATIONS:

Stores offered should strictly conform to our specifications. Deviation, if any should be clearly indicated by the tenderer in their quotation. The tenderer should also indicate the Make/type No. of the stores offered and provide catalogue(s), Technical literature(s) and sample(s), wherever necessary along with the quotations. Test certificates wherever necessary should be forwarded along with the supplies. Whenever options are called for in our specifications, the tenderer should address all such options. Wherever specifically mentioned by us the tenderer could suggest changes to specifications with appropriate response for the same.

4. The purchaser shall be under no obligation to accept the lowest or any tender and reserves the right of acceptance of the whole or any part of the tender or portion of the quantity offered and the tenderers shall supply the same at the rates quoted.
5. Corrections, if any, must be attested. All amounts shall be indicated both in words as well as in figures. Where there is difference between amounts quoted in words and figures, amount quoted in words shall prevail.
6. The Tenderer should supply along with the tender, the name of his bankers as well as the latest Income Tax Clearance Certificate duly countersigned by the Income Tax Officer of the circle concerned under the seal of his office, if required by the Purchaser.
7. The Purchaser reserves the right to place order on the successful tenderers for additional quantity upto 25% of the quantity offered by them at the rates quoted.
8. The authority of the person signing the tender, if called should be produced.
9. Complete system configuration and system and sub-system design details should have approval of the purchaser before actual fabrication or procurement process.
10. A complete set of instruction and operation manual should be supplied at the time of installation.
11. Final performance should be guaranteed at the site.

TERMS AND CONDITIONS OF CONTRACT

1. DEFINITIONS:

- a). The terms 'Purchaser' shall mean the Director, Indian Institute of Astrophysics, Bangalore-560 034.
- b). The term 'Contractor' shall mean, the person, firm or company with whom or with which the order for the supply of stores is placed and shall be deemed to include the Contractor's successors, representative, heirs, executors and administrators unless excluded by the contract.
- c). The 'Stores' shall mean that contractor agrees to supply under the contract as specified in the Purchase Order including erection of Plants and machinery and subsequent testing, should such a condition be included in the Purchase Order.
- d). The terms 'Purchase Order' shall mean the communication signed on behalf of the Purchaser by an officer duly authorized intimating the acceptance on behalf the Purchaser on the terms and conditions mentioned or referred to in the said communications accepting the tender or offer of the contractor for supply of stores or plant, machinery or equipment or part thereof.

2. PRICES:

Tenders offering firm prices will be preferred, where a price variation clause is insisted upon by a tenderer, quotations with a reasonable ceiling should be submitted. Such offers should invariably be supported by the base price taken into account at the time of tendering and also the formula for any such variations.

Duty Exemption:

Please note that we may issue "Excise duty Exemption Certificate", if acceptable under the Govt. of India notification No. 10/97 valid till 2011.

3. SECURITY DEPOSIT:

On acceptance of Tender, the Contractor shall, at the option of the Purchaser and within the period specified by him deposit with him in cash or any other form as the Purchaser may determine, Security deposit not exceeding ten percent of the value of the contract as the Purchaser shall specify. If the contractor is called upon by the purchaser to deposit 'Security' and the contractor fails to provide the security within the period specified, such failure shall constitute a breach of the contract and purchase shall be entitled to make other arrangements for the re-purchase of the stores contracted for at the risk of contractor in terms of sub-clause (ii) and (iii) of clause 10 (b) hereof and/or to recover from the contractor damages arising from such cancellation.

4. GUARANTEE AND REPLACEMENT:

- a) The contractor shall guarantee that the stores supplied shall comply fully with the specifications laid down, for material workmanship and performance.
- b) For a period of (12) twelve months after the acceptance of the stores, if any defects are discovered therein or any defects therein found to have developed under proper use arising from faulty stores, design or workmanship, contractor shall remedy such defects at his own cost provided he is called upon to do so within a period of 14 months from the date of acceptance thereof by the purchaser who shall state in writing in what respect the store or any part thereof are faulty.
- c) If in the opinion of the purchaser, it becomes necessary to replace or renew any defective stores such replacement or renewal shall be made by the Contractor free of all costs to the purchaser provided the notice informing the contractor of the defect is given by the purchaser in this regard within the said 14 months from the date of acceptance thereof.
- d) Should the contractor fail to rectify the defects, the purchaser shall have the right to reject or repair or replace at the cost of the contract -or the whole or any portion of the defective stores.

- e). The decision of the purchaser, notwithstanding any prior approval of acceptance or inspection thereof on behalf of the purchaser, as to whether or not the stores supplied by the contractor are defective or any defects has developed within the said period of 12 months or as to whether the nature of the defectives required renewal or replacement shall be final, conclusive and binding on the contractor.
- f) To fulfill guarantee conditions outlined in Clause 4(a) to (d) above, the contractor shall, at the option of the purchaser, furnish a Bank Guarantee (as prescribed by the purchaser) from a Bank approved by the purchaser for an amount equivalent to 10% of the value of the contract along with first shipment documents. On the performance and completion of the contract in all respects, the Bank Guarantee will be returned to the contractor without any interest.
- g) All the replacement stores shall also be guaranteed for a period of 12 months from the date of arrival of stores at Purchaser's site.
- h) Even while the 12 months guarantee applied to all stores in case where a greater period is called forth by our specifications then such a specification shall apply; in such cases the period of 14 months referred to in Para 4(b) and (c) shall be 'asked for' guarantee period plus two months.

5. **PACKING, FORWARDING AND INSURANCE:**

The Contractor will be held responsible for the stores being sufficiently and properly packed for transport by rail, road, sea or air, to withstand transit hazards and ensure safe arrival at the destination. The packing and marking of packing shall be done by and at the expenses of the contractor. The Purchaser will not pay separately for transit insurance, all risks in transit being exclusively of the contractor and the Purchaser shall pay only for such stores as are actually received in good condition, in accordance with contract.

6. **TEST CERTIFICATE:**

Wherever required Test Certificate should be sent along with the relevant dispatch documents.

7. **ACCEPTANCE OF STORES:**

- a) The Stores shall be tendered by the contractor for inspection at such places as may be specified by the purchaser at the Contractor's own risk, expenses and cost.
- b) It is expressly agreed that the acceptance of stores, contracted for is subject to final approval by the Purchaser, whose decision shall be final.
- c) If, in the opinion of the Purchaser all or any of the stores that do not meet the performance or quality requirements specified in the Purchase Order, they may be either rejected or accepted at the price to be fixed by the purchaser and his decision as to rejection and the prices to be fixed shall be final and binding on the contractor.
- d) If the whole or any part of the store supplied are rejected in accordance with Clause No.7 (c) above, the Purchaser shall be at the liberty, with or without notice to the Contractor, to purchase in the open market at the expenses of the Contractor, stores meeting the necessary performance and quality contracted for in place of these rejected, provided that either the purchase, or the agreement to purchase, from another supplier is made within six months from the date of rejection of the stores as aforesaid.

8. **REJECTION OF STORES:**

Rejected Stores will remain at the destination at the Contractor's risk and responsibility, if instructions for their disposal are not received from the Contractor within a period of 14 days from the date of receipt of the advice or rejection, the Purchaser or his representative has, at his discretion the right to scrap or seal or consign the rejected stores to the Contractor's address at the Contractor's entire risk and expense, freight being payable by the Contractor at actuals.

9. DELIVERY PERIOD:

- a) The time for and the date of delivery of the stores stipulated in the Purchase order shall be deemed to be the essence of the Contract, and delivery must be completed on or before the specified dates.

- b) Should the Contractor fails to deliver the stores or any consignment thereof within the period prescribed for such delivery, the Purchaser shall be entitled at his option either.
 - i) to recover from the Contractor as agreed liquidated damages and not by way of penalty, a sum of 2% of the price of any stores which the contractor has failed to deliver as aforesaid for each month or part of a month, during which the delivery of such stores may in arrears, or

 - ii) to purchase elsewhere, without notice to the Contractor on the account and at the risk of the contractor, the stores not delivered or others of similar description (where other exactly complying with the particulars are not, in the opinion of the purchaser readily procurable, such opinion being final) without canceling the Contract in respect of the consignment(s) not yet due for delivery or,

 - iii) to cancel the contract or a portion thereof, and, if so desired to purchase or authorize the purchase of stores not so delivered or others of similar description (where others exactly complying with the particulars are not, in the opinion of the purchaser readily procurable, such opinion final) at the risk and cost of the Contractor.

In the event of action being taken under sub-clause (ii) and (iii) of clause 9 above, the Contractor shall be liable for any loss which the Purchaser may sustain on that account, provided that the re-purchase, or, if there is an agreement to re-provided that the agreement, is made within (6) six months from the date of such failure. But the Contractor shall not be entitled to any gain on such re-purchase made against default. It shall not be necessary for the purchaser to serve a notice of such re-purchase on the defaulting Contractor. This right shall without prejudice to the right of the purchase to recover damages for breach of contract by the Contractor.

10. **EXTENTION OF DELIVERY TIME:**

As soon as it is apparent that Contractor dates cannot be adhered to, an application shall be sent by the Contractor to the Purchaser. If failure, on the part of the Contractor to deliver the stores in proper time shall have arisen from any cause which the Purchaser may admit as reasonable ground for an extension of the time (and his decision shall be final he may allow such additional time as he considers it to be justified by the circumstances of the case without prejudice to the Purchaser's rights to recover liquidated damages under clause 9 hereof.

11. **PAYMENT:**

Contractor's Bill will be passed only after the stores have been received, inspected and accepted by the Purchaser for payment.

12. **RECOVERY OF SUMS DUE:**

Whenever there is a breach of contract whether liquidated or not, money arises out of or under this contract against the contract, the Purchaser shall be entitled to recover such sum by appropriating, in part or while, the security deposited by the Contractor, if a Security is taken against the contract. In the event of the Security being insufficient or if no security has been taken from the Contractor, then the balance or the total sum recoverable as the case may be shall be deducted from any sum then due or which at any time thereafter may become due to the contractor under this or any other contract with the Purchaser. Should this sum be not sufficient to cover the full amount recoverable, the Contractor shall pay to the Purchaser on demand the remaining balance due. Similarly, if the purchaser has or makes any claims, whether liquidated or not, against the Contractor under any other contract with the purchaser, the payment of all moneys payable under the contract to the Contractor including the Security Deposit shall be withheld till such claims of the Purchaser are finally adjudicated upon and paid by the Contractor.

13. **INDEMNITY:**

The Contractor shall warrant and be deemed to have warranted that all stores supplied against this contract are free and clean of infringement of any patent, copy right or trade mark, and shall at all time indemnity the purchaser against all claims which may be made in respect of the stores for infringement of any right protected by patent, registration of design or trade mark and shall take all risk of accidents of damage which may cause a failure of the supply from whatever cause arising and the entire responsibility for sufficiency of all the means used by him for the fulfillment of contract

14. **ARBITRATION:**

In the event of any question, dispute or difference arising under these conditions contained in the purchase order in connection with this contract, (except as to any matters the decision of which is specially provided for by these conditions), the same shall be referred to the sole arbitration of the Head of the Purchase Officer or of some other person appointed by him. It will be no objection that the arbitrator is a Government Servant, that he has to deal with matter to which the Contract relates or that in the course of his duties as Government Servant he has expressed views on all or any of the matters in dispute binding on the parties of this Contract.

(a) **IT IS TERMS OF THIS CONTRACT:**

If the Arbitrator be the Head of the Purchase Office,

- i) in the event of his being transferred or vacating his office by resignation or otherwise, it shall be lawful for his successor-in-office either to proceed with the reference himself, or to appoint another person as arbitrator, or,
- ii) in the event of his being unwilling or unable to act for any reason, it shall be lawful for the Head of the Purchase Office to appoint another person as arbitrator or,

(b) If the Arbitrator be a Person appointed by the Head of the Purchase Officer:-

In the event of his death, neglecting or refusing to act, or resigning or being unable to act for any reason, it shall be lawful for the Head of the Purchase Office either to proceed with reference himself or to appoint another person as arbitrator in place of the outgoing arbitrator. Subject as aforesaid, the Arbitration Act, 1940 and the rules there under and any statutory modifications thereof for the time being in force shall be deemed to apply to the arbitration proceedings under this clause. The Arbitrator shall have the power to extend with the consent of the Purchaser and the Contractor the time for making a publishing the award. The venue of Arbitration shall be the place as the Purchaser. In his absolute discretion may determine. Work under the contract shall if reasonably possible, continue during Arbitration proceedings.

15. **COUNTER TERMS AND CONDITIONS OF SUPPLIERS:**

Where Counter Terms and Conditions/printed or cyclostyled conditions have been offered by the Supplier, the same shall not be deemed to have been accepted by the Purchaser, unless specific written acceptance thereof is obtained.

16. **SECURITY FOR PURCHASER'S MATERIAL(S):**

Successful Tenderer will have to furnish in the form of a Bank Guarantee or any other form as called for by the Purchaser towards adequate security for the materials/property provided by the Purchaser for the due execution of the Contract.