



Phone: 25530672-76

FAX : 25534043

INDIAN INSTITUTE OF ASTROPHYSICS

IIND BLOCK, SARJAPUR ROAD, KORAMANGALA,
BANGALORE-560 034

PUBLIC TENDER NOTICE NO: PR/TBC/UVIT-IIA/CAP/178 DT:11th SEPTEMBER 2007

The Director, Indian Institute of Astrophysics invites Quotations/Bids from reputed firms for following items / specifications. Hence the firm(s) interested in offering bids should have executed similar items/works.

Sl.No.	Description In Brief	Quantity	E.M.D (refundable) Rs.	Tender Fee (non-refundable) Rs.
01.	Design, fabrication, testing and Installation of Thermal Baking Chamber as per the proposed sketch in the enclosed RFP	One No.	75,000/-	250/-
02.	Pumps and gauges as per the Specification in the enclosed RFP	Two sets.		

Note: (1) The Tender documents with Specification details are available on IIA website www.iiap.res.in/tenders.htm. Hence the interested tenderers may at their option download the same from our website (as no hard copies of Tender documents is/are provided from this office) and submit their offers along with EMD (refundable) & Tender fee (non-refundable) prescribed therein, only in the form of Demand Draft drawn in favour of Director, IIA). However, your offers (both Technical & Commercial/price bids) should be superscribed in separate envelopes mentioning the tender notice no., Date of opening, and submit both the Bids in a sealed envelopes addressed in favour of Director, Indian Institute of Astrophysics, Bangalore – 560 034.

2. The firms who fulfill the following requirements shall be eligible to submit their Bids. Joint ventures are not acceptable.

(a) Tendering Company shall be professionally managed and equipped with facility for the design, fabrication, testing, supply and maintenance of tendered items.

(b) Tenderer should have completed, in the last 3 financial years (i.e., current year and two previous financial years) atleast one similar single work for a minimum value of 40% of Rs.30 Lacs.

(c)The total contract amount received during the last 3 financial years, and the current financial year should be a minimum of 150% of the above mentioned value. The tenderer should submit Audited Balance Sheet duly certified by the Chartered Accountant to this effect. They should also submit Bankers Solvency Certificate to a minimum of Rs.30 Lacs.

(d) The Private Body Contractor shall be required to produce the TDS Certificate indicating the Income Tax deducted by the client for the execution of similar items, completed individually of value not less than Rs.30 Lakhs.

3. Both Technical/Commercial/price Bids supported by the above information should be submitted in Sealed envelope duly superscribed with the name of work. The completed Bids will be received by this office **upto 1500 Hrs. on 22nd October 2007.**

4. If any information furnished by the tenderers is found incorrect at a later stage, the firm shall be liable to be debarred from tendering and taking up of work in IIA. The Institute reserves the right to verify the particulars furnished by the tenderers.

5. The interested tenderers may contact **Mr.S.Sriram**, with prior permission on or before **10th October 2007**, to discuss Technical clarifications, if any before submitting both Technical / Price bids.

6.The firms should submit both Technical and Commercial/Price bids separately superscribed along with EMD/Tender fee of prescribed amount **upto 1500 Hrs. Latest by 22nd October 2007** The Technical Bids will be opened in presence of the bidders or their authorized representatives **at 1530 Hrs. on 22nd October 2007.**

7.Incomplete Technical Bids are liable for rejection. Commercial/price bids will be considered only for the Qualified Technical Bidders.

8.Late & / delayed offer will not be considered.

9.IIA is not responsible for any delay / loss of documents in transit.

10. No bids will be considered if prescribed EMD and Tender Fee are not found with Technical bids Part I.

10.The Commercial/Price Bids will be opened on **12th November 2007 at 1530 Hrs.**of those firms technically qualified in the presence of such bidders or their nominated representatives.

11.IIA reserves the right to reject any or all tenders without assigning any reasons.

**Administrative Officer
IIA, Bangalore-34**

Annexure-I
IMPORTANT: TWO PART TENDER INSTRUCTIONS

1. It is proposed to have a two cover system for this tender.
Part I: (a) Technical part (without price) is one cover.
Part II: (b) Commercial /Price part alone is another cover.

2. TECHNICAL PART:

Technical part should clearly indicate the technical details. A compliance Statement indicating whether the specifications are met is to be submitted with reasons for deviations if any. Complete with Drawings, in relevant to the offer are also to be enclosed to the technical part.

2. COMMERCIAL PART (without price)

Commercial part should indicate commercial terms like, delivery period, place of delivery, payment terms, validity, warranty/guarantee etc. and should be sent along with the price part. The Technical part should be kept in one cover along with EMD & Tender Fees superscribing tender number and due date and should be sealed.

3. **COMMERCIAL AND PRICE PART** alone should be kept in a separate cover superscribing tender number and due date.

5. The technical part in one cover and **Commercial and Price part** in another cover should be put in one large cover, and should be superscribed with the tender number, due date and time of opening.

4. The cover should be sent to the following address:- **THE DIRECTOR, INDIAN INSTITUTE OF ASTROPHYSICS., IIND BLOCK, KORAMANGALA, BANGALORE – 560 034.**

6. The offer should be valid for a minimum period of 120 days from the due Date.

7. Offer shall be submitted in sealed cover only as said above.

8. No conditional discounts will be allowed.

9. EMD & Tender fee of prescribed value shall be sent along with the Technical Bids) tenders in the form of demand draft only in favour of “The Director, Indian Institute of Astrophysics., Bangalore” drawn from any Indian Nationalised / reputed Banks in India.

10. Tender shall be submitted as above without fail.

Phone: 25530672-676
Fax : 25534043
Grams: ASTRON

INDIAN INSTITUTE OF ASTROPHYSICS
IInd Block, Koramangala, Bangalore-560 034

No.PR/TBC/UVIT-IIA/CAP/178

Dated: August 2007

M/s.

Dear Sirs,

The Director, Indian Institute of Astrophysics, Bangalore invites Sealed Tenders for the supply of Stores detailed in the Tender Form hereto annexed. The Tender Terms enclosed are also may be noted carefully. If you are in a position to quote for the supply in accordance with the requirement, please submit your quotation in the attached Tender Form also.

Your Tender (Technical, Commercial & price Bids) must reach this office on or before the date and time indicated in the Tender Schedule.

Thanking you,

Yours faithfully,

Encl: as above.

(AJ Raghupathy)
Admn. Officer
For Director

INDIAN INSTITUTE OF ASTROPHYSICS
BANGALORE-560 034

PUBLIC TENDER DOCUMENT NO:PR/TBC/UVIT-IIA/CAP/178
DT: _____, 2007

TENDER FORM

FROM:

TO

THE DIRECTOR,
Indian Institute of Astrophysics.,
Bangalore-560 034.

Sir,

I/We hereby offer to supply the stores indicated below at the price hereunder quoted and agree to hold this offer open till_____. I/We shall be bound to supply the store hereby offered upon the issue of the Purchase Order communicating to the acceptance thereof on or before the expiry of the last mentioned date. You are at liberty to accept any one or more of the items of such stores. I/We notwithstanding that the offer in this tender has not been accepted in whole, shall be bound to supply such items and such portion or portions of one or more of the items as may be specified in the said Purchase Order communicating the acceptance.

Sl.No.	Description of the item(s)	Quantity	Unit	Rate	Dely.	Period
01.	Design, fabrication, testing and Installation of Thermal Baking Chamber as per the proposed sketch in the enclosed RFP					

Place at which the Delivery is required : at 2nd Block, Koramangala, Bangalore

Date by which the supplies are required : weeks FDO.

2. I/We have understood the items of the tender annexed to the invitation to this Public Tender and have thoroughly examined the specifications/drawing and /or pattern quoted or referred to herein and/are fully aware of the nature of the stores required and my/our offer is to supply the stores strictly in accordance with the requirements subject to the terms and conditions contained in the Purchase Order, if communicated on the acceptance of this tender either in whole or in part.

Date:

Signature and seal of Tenderer

Annexure II



Request For Proposal

THERMAL BAKING CHAMBER FOR UVIT COMPONENTS

July 2007

**Indian Institute of Astrophysics
Bangalore-560 034**

TABLE OF CONTENTS

- 1.0 Vacuum chamber
 - 1.1 Scope of the work
 - 1.2 Chamber Specification
- 2.0 Testing and Inspection
 - 2.1 Dimensional Inspection
 - 2.2 Installation
 - 2.3 Demonstration and Final activities to be done
 - 2.4 Warranty
 - 2.5 Statements And References
 - 2.6 Quotation
- 3.0 Electrical Control and Instrumentation System for Thermal Baking Vacuum Chamber
 - 3.1 Requirements
 - 3.1.1 Switch panel
 - 3.1.2 Switch Gear
 - 3.1.3 Switch Gear Equipment
 - 3.1.4 Cables
 - 3.1.5 Temperature Controllers
 - 3.1.6 Data Logging System
 - 3.1.7 Alarm Panel
 - 3.1.8 Ammeter /Voltmeter Panel
 - 4.0 Vacuum chamber diagram
 - 4.1 Flange size of the chamber
 - 4.2 Specifications for pumps and gauges
- Appendix-A: Pumping details for the chamber
- Appendix-B: Specifications of RGA
- Appendix-C: Specifications of TQCM

THERMAL BAKING CHAMBER FOR UVIT COMPONENTS

Ultra Violet Imaging Telescope (UVIT) is one of the payload of ASTROSAT is being built by Indian Institute of Astrophysics (IIA). In order to realize a suitable vacuum system for the bake out of the component tests of UVIT, the following has to be considered.

1.0 Vacuum Chamber

One number of 600mm diameter and 700mm length horizontal axis cylindrical vacuum chamber with a hinged door on one side is required.

1.1 Scope of the work

Scope of work involves detailed design to match the sketch in our drawing, fabrication, testing of the item, delivery, installation and demonstration of performances of the vacuum chamber in our laboratory. Pumps and gauges shall be purchased by the vendors; if required a certificate for duty free import will be issued by IIA for these pumps. Spares for the chambers and pump for three years of operation should be provided.

IIA shall purchase Thermally Controlled Quartz Crystal Microbalance and Residual Gas Analyzer.

1.2 Chamber Specification

- Chamber size: 600mm diameter and 700mm length cylindrical chamber with hinged door on front end and fixed rear end.
- The front-end dish and the rear end dish should be torispherical dish.
- Material Constructions (Chamber): Stainless steel of grade AISI 304 L (ASTM standard of grade SA-240-TP-304L)
- Size and shape: As per the enclosed drawing
- Ultimate Vacuum: 1×10^{-6} mbar (for design/fabrication purpose).
(For vacuum compatibility)
- Vacuum leak tightness
 - Individual joints: 1×10^{-9} std cc/s for helium
 - Gross leak rate: Pressure to raise not more than 0.01 mbar after a lapse of 24 hrs after pumping.
- Welding: The root pass weld shall be TIG Argon arc welding Following ASME code sec. IX. The subsequent welding passes shall be done using suitable stainless steel electrode and manual arc welding. All inside welds are to be continuous and outside surfaces can be staggered.

- Surface Finish:
 - Inside surfaces: Electro polished to achieve 0.4 microns Ra value finish.
 - Outside surfaces of chambers: All the chamber outside surfaces including nozzles & flange surfaces shall be buffed smooth to mirror finish.
- Weld joint finish: All weld joint inside vacuum chamber should be sand blasted
- Weld joint: Port holes/nozzles shall be located such that the same is not opened at the weld joints of sheets/plates and largest available plates shall be used to reduce welding joints.
- Distortion due to welding: The distortion due to welding shall be less than 1mm in 1000mm. Main door flange shall be welded to chamber shell making use of a collar to minimize distortion.
- 'O' Rings grooves: All 'O' ring grooves shall be trapezoidal in shape.
- 'O' ring: Made up of 'VITON' with shore 'D' hardness of 60 ± 5 .
- Port holes: As per the drawing and extras required for the functions.
- Port pipes: Pipes used for the ports are to be seamless S.S 304L pipes of ASTM Standard of Grade SA-312-TP-304L
- Finish of flanges: All the flange surfaces, 'O' Ring grooves and main door flange shall carry of finish better than 1.6 microns and should be scratch-free/scriber mark free for ensuring leak free sealing of the 'O' Rings.
- Blank off Flanges: All nozzles/Port holes shall be provided with suitable S.S. blank off flanges with fasteners.
- Material of Flanges: All flanges shall be fabricated from ASTM standard of grade SA-182-304L
- Fasteners: All the ports are to be fitted with matching flanges and fixed with required numbers of S.S. 304/S.S.304L bolts, nuts and washers and Viton 'O' rings as per the DN standards.
- External Chamber Mounting Structure: Chamber shall be mounted on saddle as per Drawing
- Heaters shall be tubular, welded to the outside of the chamber, made of S.S material.
- Inside the cylinder, 4 posts (dimensions and locations to be specified at a later time) shall be fixed (welded). On these posts a perforated sheet (with holes of 6 mm diameter, thickness 2 mm) shall be placed as a platform for keeping components for baking.

2.0 Testing and Inspection

2.1 Dimensional Inspection:

- Shell & Dish plates, nozzles, and flanges tests are per relevant ASTM standards for chemical composition and mechanical properties.
- Radiographic inspection of welded areas:- At least 10% of vacuum welding length shall be X-ray tested and 100% of welding length shall be X-ray tested if fails are detected in test.
- Dye penetrant test: - All the welded joint including root welding (ie: 100%) should be subjected to dye penetrant test.
- MSLD test: - All weld joints shall be subjected to mass spectrometer leak detection (MSLD test) and no weld joint shall have a leak rate beyond 1×10^{-9} std cc/sec for helium.
- Acceptance test: - Vendor/Supplier shall carry out acceptance tests which will be witnessed by our Engineers at vendor's site prior to delivery and at the vendor's/supplier's cost.
- Test certificates: - All the test certificates shall be supplied along with delivery.

2.2 Installation

Chamber is to be installed in the Prof. M. G. K. Menon Laboratory of IIA, CREST, Hoskote

2.3 Demonstration and Final activities to be done

1. Movement of the dished door.
2. Mating of dished end with the cylindrical chamber – flanges to be flushed to 0.1 mm.
3. Fixing of clamps for chamber to mate with dished end door and arresting of dished ends tie-rods with lock nuts.
4. Demonstration of vacuum in the chamber using our vacuum pumps to the satisfactory level of 1×10^{-6} mbar or better.

2.4 Warranty

The supplier should provide a minimum of 2-year warranty for poor performance, workmanship, parts, materials, or welding defects.

2.5 Statements And References

- Vendor should provide compliance statements for all of our specifications in points-wise and any deviation shall be clearly indicated with merits
- Vendor should provide the product heritage for fabricating and supplying similar kind of vacuum chamber along with company profile and facilities of vendor. Vendor should clearly indicate availability of manufacturing, inspection and testing facilities.
- References of two customers with name of company, contact person, address, telephone number and fax number shall be given in quote.

2.6 Quotation

The technical bid and commercial bid shall be given separately.

3.0 Electrical Control and Instrumentation System for Thermal Baking Vacuum Chamber

3.1 Requirements

The control and instrumentation system comprises of electric switch, gear and protection equipment to control various machines such as heaters etc and instrumentation system to monitor system parameters such as vacuum and temperature, all of them housed in a standard 19” rack located in the proximity of the vacuum chamber. The control and instrumentation system, must be made to industry standards providing safe starting of various electric systems, to provide adequate protection against electric faults, to facilitate easy operation, safety interlocks to take care of operator errors and equipment failures and also to take care of equipment and human safety. The material of the monitoring rack has to be SS 304. RGA and TQCM controller has to be gone to the rack.

The following is the details of some of the units built into the control system:

3.1.1 Switch Panel

All the loads must be switched through illuminated On/OFF push buttons. There has to be one master control emergency mushroom button with lock facility. ON/OFF switches are mounted on a switch panel of appropriate size, with corresponding name of the load screen printed on it.

3.1.2 Switch Gear

The Control switch gear and protection equipment should be provided for all systems as per industry standards to facilitate safe starting of various electric systems, to provide adequate protection against electric faults, to provide easy operation, safety interlocks to take care of operator errors and equipment failures and also to take care of human safety.

3.1.3 Switch Gear Equipment

- All switchgear must be of best quality and confirm to ISI specifications.
- A mains MCB of adequate capacity should be provided for protection as well as isolation purposes.
- A single phasing preventor is to be provided to safe guard all the three phase systems from supply failures such as phase fail etc.
- Each system such as Diaphragm pump, Turbo molecular pump etc are to be provided with individual starter comprising MCB/Fuse, Overload relay and a contactor all with adequate rating.
- All load terminals are to be terminated through connectors of proper rating.
- All wiring must be wired through plastic channels safely and aesthetically.
- Wiring must have terminal markings for tracing during faultfinding.
- The wiring of the control system must meet good electrical insulation standards.
- The system must be provided with good grounding.
- Additional 5 mains outlets of 6/15 Amp each to be provided in the rack for miscellaneous use.

3.1.4 Cables

The internal wiring must be done with high quality wires that confirm to IS Specifications. Proper color-coding for different phases must be followed as per standards.

The power cables between the terminal connectors in the control system to the respective remotely located loads must be provided. The cables must confirm to the IS specifications.

3.1.5 Temperature Controllers

The sensors can be Platinum resistance thermometers. The chamber temperature is controlled using PID controller. The controller drives an SSR to switch chamber heaters ON/OFF.

Temperature required: From room temperature to 120°C, controlled to $\pm 2^\circ\text{C}$, continuously. With 20 kg S.S component inside the hot chamber, 120°C should reach in 3 hours.

The vendor must give a technical note explaining how the temperature is limited to set value in case of a failure of the controller.

3.1.6 Data Logging System

The data logging system should monitor temperature information from many locations, through various types sensors such as thermocouples of different type.

3.1.7 Alarm Panel

The control and instrumentation panel should also house an alarm panel containing the following:

Status indicators: DOOR (chamber) OPENED, DOOR CLOSED, heater ON/OFF.

3.1.8 Ammeter /Voltmeter Panel

The Ammeter /Voltmeter Panel should contain digital or analogue Voltmeter and Ammeters to measure incoming supply voltage and current.

4. Vacuum chamber diagram

Time of delivery: 4 months (after releasing purchase order)

The schematic diagram of the vacuum chamber is given below,

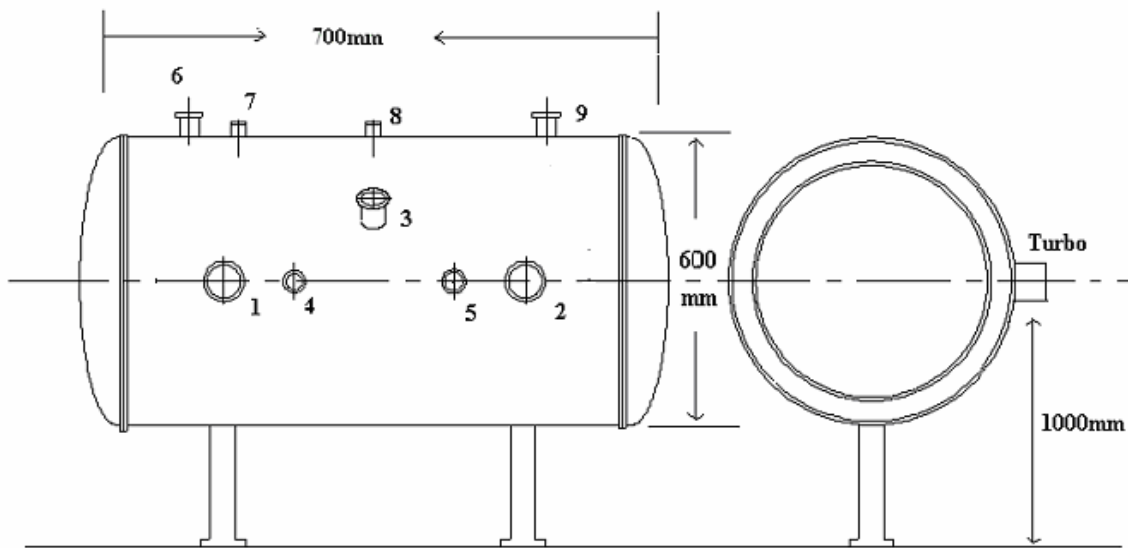

Fig1: Thermal Baking Vacuum Chamber

4.1 Flange size of the chamber

FLANGES	SIZE
1. For turbo	CF 160
2. For turbo	CF 160
3. Extra port	CF 63
4. For Roughing	CF 40
5. For Roughing	CF 40
6. For Gauge	CF 40
7. RGA	2.75" CF
8. TQCM	2.050" CF
9. For Gauge	CF 40

- All the port shall be provided with necessary O Rings, Clamps and Fasteners wherever applicable.
- All the flanges to have pipes for running cooling water so as to block heat flow from the hot chamber; mounting of the flange should minimize heat flow.

Sample calculation of heat flow to the flanges

For a tube of thickness 1mm and length 100mm made up of stainless steel, the thermal conductance corresponding each port diameter is given below.

Port	Diameter (mm)	Thermal conductance of the tube (mW/K)	If $T_2-T_1=100\text{ }^{\circ}\text{C}$ Then heat flow (W)
Roughing pump	65	30	3
Turbo pump	180	85	8.5
RGA	69.85	33	3.3
TQCM	52.07	25	2.5
Gauge	65	30	3
Extra	95	45	4.5

4.2 Specifications For Pumps and Gauges

1. High vacuum Pump - Compact Turbo – 2 Nos
Pumping speed = 510 l/s (or equivalent)

Bearing on the vacuum side to be magnetic, bakable at $100\text{ }^{\circ}\text{C}$.

2. Fore Vacuum pump
Dry pump – 2Nos

Pumping Speed = $30\text{ m}^3/\text{h}$

3. Vacuum Gauges – 2 Nos
Pressure range: 1 atm – 10^{-6} mbars

Flange type: DN CF40

Standard ports:

The following table gives the ports requirements:

Description of the port (Circular)	Size Dia	Qty	Location	Remarks
Turbo Pump port	CF 160 (180mm)	Two	Chamber side wall	Required for the high vacuum pump for the final vacuum
Roughing pump port	<i>CF 40</i> (65mm)	Two	Chamber side Wall	Required for roughing pump for initial vacuum
Extra port	CF 63 (95mm)	One	Chamber side wall	Required for Any future requirement
RGA	2.75" CF	One	Top	For connecting the Residual Gas Analyzer
TQCM	2.050" CF	One	Top	For connecting the Thermally Controlled Quartz crystal microbalance
Gauge Ports	CF 40 (65mm)	Two	Top	For connecting The Compact Full range Gauges

APPENDIX-A

PUMPING DETAILS FOR THE CHAMBER

1. *Structural Design*

Chamber Material = SS 304 L

Vacuum chamber length = 700mm

Vacuum chamber Diameter = 600mm

Design Temperature = 120° C

Design pressure = 1 Kg/cm²

2. *Pump details*

Pump	Purpose	Pumping Speed	Qty
Turbo pump	High vacuum	500 l/s (Each)	2
Dry pump	Fore vacuum	10 m ³ /hr (Each)	2

Total Volume of the vacuum chamber \approx 197 litre.

Total Surface Area Chamber \approx 1.885 m²

3. **Roughing time calculations:**(For Dry pump)

PRESSURE (mbar)		PUMPING SPEED (S _P) (m ³ /hr)	PUMPING SPEED (S _P) (ls/min)
From (P ₁)	To (P ₂)		
1000	100	10	166.67
100	10	10	166.67
10	1	5	83.33

Pumping Time, **T = 2.3* (V/S) log (P₁/P₂)**

T₁=2.7185min, T₂=2.7185min, T₃=5.4374min

Total Time, T = T₁+ T₂+ T₃ = 10.8744 min.

4. Time calculations for Turbo Pump

Pressure (mbar)		Pumping speed (l/s)
From (P ₁)	To (P ₂)	
10 ⁻⁰	10 ⁻¹	75
10 ⁻¹	10 ⁻²	200
10 ⁻²	10 ⁻³	450
10 ⁻³	10 ⁻⁵	510

Pumping Time, **T = 2.3* (V/S) log (P₁/P₂)**

T₁= 6.04sec, T₂=2.2655sec, T₃ =1.01sec, T₄ = 1.778sec

Total Time, T = T₁+ T₂+ T₃+T₄= 11.0935sec

5. Degassing rate: (all to be checked)

Material: SS 304L = 1x10⁻⁸ mbar l/sec cm²

6. Gas Load:

Gas Load= Surface Area X Degassing Rate
Chamber (SS 304L) = 1.885 x10⁻⁴ mbar l/sec

7. Ultimate vacuum Achieved:

Ultimate vacuum Achieved = (Total Gas Load / Effective Pumping Speed)

(Note: effective pumping speed= speed of turbo pump 510 l/s + conductance of the pipe connecting the chamber and pump)

$$\begin{aligned} &= (1.885 \times 10^{-4} / 510) \text{ mbar} \\ &= 3.69 \times 10^{-7} \text{ mbar} \end{aligned}$$

APPENDIX B

SPECIFICATIONS OF RGA (RGA from SRS)

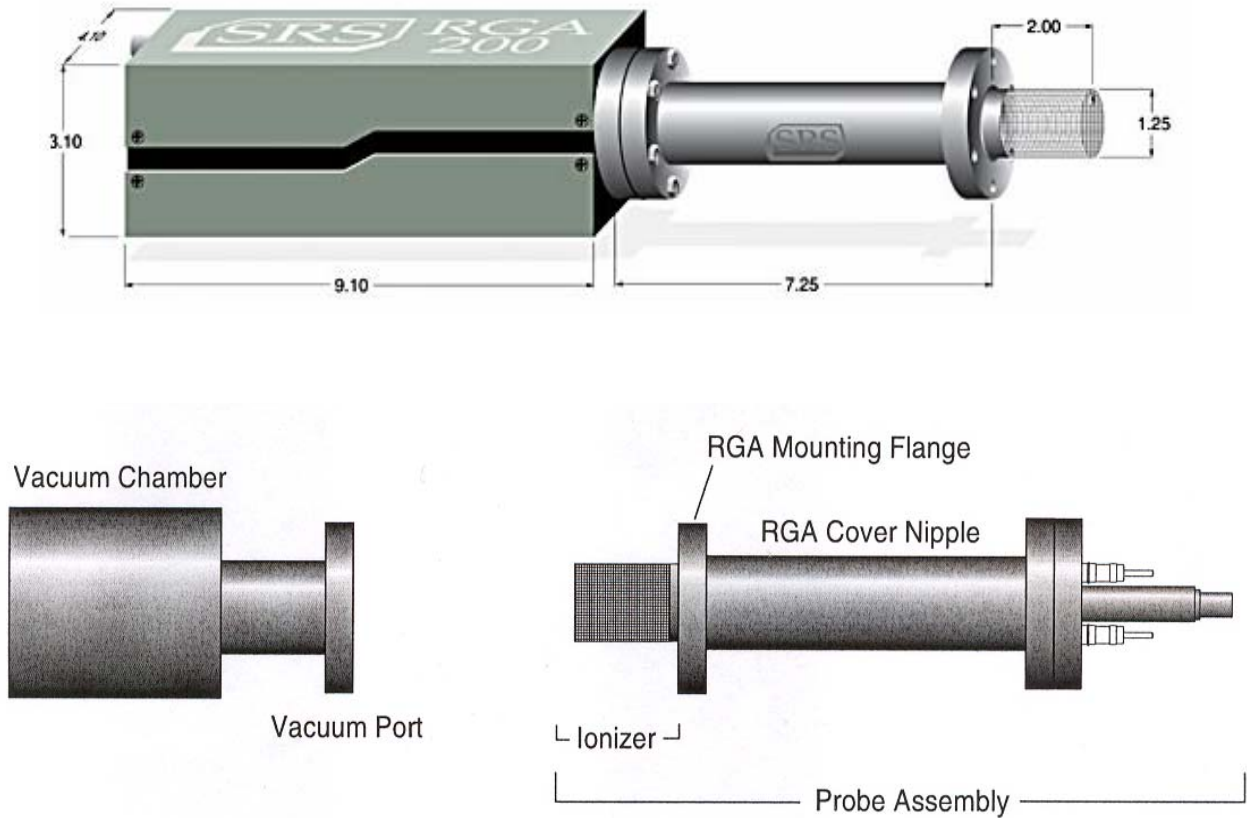

Fig: RGA Probe Installation

Residual Gas Analyzer; A laboratory instrument designed to evaluate partial pressures of residual gasses in vacuum, and which is able to resolve partial pressures to less than 1 amu (atomic mass unit).

Specifications

Operational

Mass Range:

RGA100 1 to 100 amu

RGA200 1 to 200 amu

RGA300 1 to 300 amu

Mass filter type Quadrupole
(Cylindrical rods, rod diameter: 0.25", rod length: 4.5")

Detector type Faraday cup (FC) - standard
Electron multiplier (CDEM) - optional

Resolution Better than 0.5 amu @ 10% peak height
(per AVS standard 2.3). Adjustable to constant peak width throughout the entire mass range.

Sensitivity (A/Torr)* $2 \cdot 10^{-4}$ (FC)
<200 (CDEM). User adjustable throughout high voltage range.

Minimum detectable partial pressure (MDPP)* $5 \cdot 10^{-11}$ Torr (FC).
 $5 \cdot 10^{-14}$ Torr (CDEM).

Operating pressure range 10^{-4} Torr to UHV (FC)
 10^{-6} Torr to UHV (CDEM)

Max. bakeout temperature (without ECU) 300°C

Operating Temperature 70°C (max.)

Recommended bakeout temperature 200°C (O100HJR Heater Jacket recommended)

Total press. measurement Available with FC measurements only

* Measured with N₂ @ 28 amu with 1 amu full peak width @ 10% height, 70 eV electron energy, 12 eV ion energy and 1 mA electron emission current.

Ionizer

Design Open ion source, cylindrical symmetry.

Operation Electron impact ionization.

Material Stainless steel, type 304.

Max. bakeout temperature (without ECU)	300°C
Operating Temperature	70°C (max.)
Recommended bakeout temperature	200°C (O100HJR Heater Jacket recommended)
Total press. measurement	Available with FC measurements only

* Measured with N₂ @ 28 amu with 1 amu full peak width @ 10% height, 70 eV electron energy, 12 eV ion energy and 1 mA electron emission current.

Ionizer

Design	Open ion source, cylindrical symmetry.
Operation	Electron impact ionization.
Material	Stainless steel, type 304.

Degas	1 to 10 W Degas ramp-up.
Electron energy	25 to 105 V, programmable.
Ion energy	8 or 12 V, programmable.
Focus voltage	0 to 150 V, programmable.
Electron emission current	0 to 3.5 mA, programmable.

General

Probe dimension	8.75" from flange face to top of ionizer
Probe insertion	2.0"
Probe mounting flange	2.75" CF
Minimum port I.D.	1.375"
ECU dimensions	9.1" x 4.1"x 3.1". Easily separated from the probe for bakeout.
LED indicators	Power (ON/OFF), Filament (ON/OFF), Degas (ON/OFF), Elec. mult. (ON/OFF), RS-232 (Busy signal), Error, Leak, and Burnt Filament.
Computer interface	RS-232C, 28,800 Baud with high level command set and fully enabled RTS/CTS handshaking.
Software	Windows OS based application.

APPENDIX C

Thermally Controlled Quartz Crystal Microbalance: A laboratory instrument designed to detect changes in the amount of molecular surface contamination on a thermally controlled surface.

SPECIFICATIONS OF TQCM: (MARK10TQCM from QCM research)

Specifications			
	Mass Sensitivity	Mass Range	
10 MHz Crystal	2.26×10^8 (Hz/g)cm ²	$\sim 4.42 \times 10^{-4}$ g/cm ²	
15 MHz Crystal	5.09×10^8 (Hz/g)cm ²	$\sim 2.95 \times 10^{-4}$ g/cm ²	
Sensor Output	1 to ~ 250 KHz	Output Impedance	12 K Ohms
Temperature Range	-199 to 100°C - Passive -80 to 100°C - Active	Pressure	Ambient to Hard Vacuum
Peltier Heat Load	6.25 W	Supply Voltage	8 to 12 Vdc (10V nom.)
Electronics: Power Signal Amplitude Voltage Sensitivity	~ 120 mW @ 10Vdc > 6 to 10Vpp < 23 Hz/V	Dimensions: Body Heat Sink	31.75mm (1.250") dia x 71.04mm (2.797") long 52.07mm (2.050") dia x 7.62mm (0.300") thick
Weight	120 g		



Annexure – III

INSTRUCTIONS TO TENDERERS

1. Tenders should be sent in sealed and superscribed envelopes with mention of Tender No. date and date of opening.
2. Late and Delayed Tender will not be considered at all.
3. Duties, Taxes where legally leviable and intended to be claimed should be distinctly shown separately in the Tender.
4. As a Govt. of India Department, this office is exempted from the payment of Octroi Duty and similar local levies (but not providing any C or D forms). Tenderers shall ensure that necessary exemption certificates are obtained from the officer concerned to avoid any payment of such levies.
5. a) Your quotation should be valid for 120 days from the date of opening of tender.
b) Prices are required to be quoted accordingly to the units indicated in the annexed tender form. When quotations are given in terms of units other than those specified in the tender form, relationship between the two sets of units must be furnished.
6. Preference will be given to those tenders offering supplies from ready stocks and on the basis of F.O.R Destination/Free door delivery at Site.
7. a) All available Technical Literature(s), Catalogue(s) and other data in support of the specifications and details of the item(s) should be furnished along with the offer.
b) Samples, if any, called for, should be submitted free of all charges by the tenderer and the Purchaser shall not be responsible for any loss or damage thereof due to any reason whatsoever. In the event of non-acceptance of tender, the tenderer shall have to remove the samples at his own expense.
c) Approximate net and gross weight of the items offered shall be indicated in your offer. If dimensional details are available the same should be indicated in your offer.

d) SPECIFICATIONS:

Stores offered should strictly conform to our specifications. Deviation, if any should be clearly indicated by the tenderer in their quotation. The tenderer should also indicate the Make/type No. of the stores offered and provide catalogue(s), Technical literature(s) and sample(s), wherever necessary along with the quotations. Test certificates wherever necessary should be forwarded along with the supplies. Whenever options are called for in our specifications, the tenderer should address all such options. Wherever specifically mentioned by us the tenderer could suggest changes to specifications with appropriate response for the same.

1. The purchaser shall be under no obligation to accept the lowest or any tender and reserves the right of acceptance of the whole or any part of the tender or portion of the quantity offered and the tenderers shall supply the same at the rates quoted.
2. Corrections, if any, must be attested. All amounts shall be indicated both in words as well as in figures. Where there is difference between amounts quoted in words and figures, amount quoted in words shall prevail.
3. The Tenderer should supply along with the tender, the name of his bankers as well as the latest Income Tax Clearance Certificate duly countersigned by the Income Tax Officer of the circle concerned under the seal of his office.
4. The Purchaser reserves the right to place order on the successful tenderers for additional quantity upto 25% of the quantity offered by them at the rates quoted.
5. The authority of the person signing the tender, if called should be produced.
6. Complete system configuration and sub-system design details should have approval of the purchaser before actual fabrication or procurement process.
7. A complete set of instruction and operation manual should be supplied at the time of installation.
8. Final performance should be guaranteed at the site.

TERMS AND CONDITIONS OF CONTRACT

1. DEFINITIONS:

- a). The terms 'Purchaser' shall mean the Director, Indian Institute of Astrophysics, Bangalore-560 034.
- b). The term 'Contractor' shall mean, the person, firm or company with whom or with which the order for the supply of stores is placed and shall be deemed to include the Contractor's successors, representative, heirs, executors and administrators unless excluded by the contract.
- c). The 'Stores' shall mean that contractor agrees to supply under the contract as specified in the Purchase Order including erection of Plants and machinery and subsequent testing, should such a condition be included in the Purchase Order.
- d). The terms 'Purchase Order' shall mean the communication signed on behalf of the Purchaser by an officer duly authorized intimating the acceptance on behalf the Purchaser on the terms and conditions mentioned or referred to in the said communications accepting the tender or offer of the contractor for supply of stores or plant, machinery or equipment or part thereof.

2. PRICES:

Tenders, offering firm prices will be preferred, where a price variation clause is insisted upon by a tenderer, quotations with a reasonable ceiling should be submitted. Such offers should invariably be supported by the base price taken into account at the time of tendering and also the formula for any such variations.

3. DUTY EXEMPTION

- (a) Any essential Equipment/part of the equipment can be imported for which "Duty Exemption Certificate" will be provided by IIA as an actual user basis. But not against high sea sales procedures.
- (b) Excise duty exemption certificate will be provided if considered against the categories of items tendered, under the Govt. of India Notification No. 10/97 valid till 2011.

4. SECURITY DEPOSIT:

On acceptance of Tender, the Contractor shall, at the option of the Purchaser and within the period specified by him deposit with him in cash or any other form as the Purchaser may determine, Security deposit not exceeding ten percent of the value of the contract as the Purchaser shall specify. If the contractor is called upon by the purchaser to deposit 'Security' and the contractor fails to provide the security within the period specified, such failure shall constitute a breach of the contract and purchase shall be entitled to make other arrangements for the re-purchase of the stores contracted for at the risk of contractor in terms of sub-clause (ii) and (iii) of clause 10 (b) hereof and/or to recover from the contractor damages arising from such cancellation.

5. GUARANTEE AND REPLACEMENT:

- a) The contractor shall guarantee that the stores supplied shall comply fully with the specifications laid down, for material workmanship and performance.
- b) For a period of (12) twelve months after the acceptance of the stores, if any defects are discovered therein or any defects therein found to have developed under proper use arising from faulty stores, design or workmanship, contractor shall remedy such defects at his own cost provided he is called upon to do so within a period of 14 months from the date of acceptance thereof by the purchaser who shall state in writing in what respect the store or any part thereof are faulty.
- c) If in the opinion of the purchaser, it becomes necessary to replace or renew any defective stores such replacement or renewal shall be made by the Contractor free of all costs to the purchaser provided the notice informing the contractor of the defect is given by the purchaser in this regard within the said 14 months from the date of acceptance thereof.
- d) Should the contractor fail to rectify the defects, the purchaser shall have the right to reject or repair or replace at the cost of the contractor the whole or any portion of the defective stores.
- e) The decision of the purchaser, notwithstanding any prior approval of acceptance or inspection thereof on behalf of the purchaser, as to whether or not the stores supplied by the contractor are defective or any defects has developed within the said period of 12 months or as to whether the nature of the defectives required renewal or replacement shall be final, conclusive and binding on the contractor

f) To fulfill guarantee conditions outlined in Clause 5(a) to (d) above, the contractor shall, at the option of the purchaser, furnish a Bank Guarantee (as prescribed by the purchaser) from a Bank approved by the purchaser for an amount equivalent to 10% of the value of the contract along with first shipment documents. On the performance and completion of the contract in all respects, the Bank Guarantee will be returned to the contractor without any interest.

g) All the replacement stores shall also be guaranteed for a period of 12 months from the date of arrival of stores at Purchaser's site.

h) Even while the 12 months guarantee applied to all stores in case where a greater period is called forth by our specifications then such a specification shall apply; in such cases the period of 14 months referred to in Para 5(b) and (c) shall be 'asked for' guarantee period plus two months.

6. PACKING, FORWARDING AND INSURANCE:

The Contractor will be held responsible for the stores being sufficiently and properly packed for transport by rail, road, sea or air, to withstand transit hazards and ensure safe arrival at the destination. The packing and marking of packing shall be done by and at the expenses of the contractor. The Purchaser will not pay separately for transit insurance, all risks in transit being exclusively of the contractor and the Purchaser shall pay only for such stores as are actually received in good condition, in accordance with contract.

7. TEST CERTIFICATE:

Wherever required Test Certificate should be sent along with the relevant dispatch documents.

8. ACCEPTANCE OF STORES:

- a) The Stores shall be tendered by the contractor for inspection at such places as may be specified by the purchaser at the Contractor's own risk, expenses and cost.
- b) It is expressly agreed that the acceptance of stores, contracted for is subject to final approval by the Purchaser, whose decision shall be final.
- c) If, in the opinion of the Purchaser all or any of the stores that do not meet the performance or quality requirements specified in the Purchase Order, they may be either rejected or accepted at the price to be fixed by the purchaser and his decision as to rejection and the prices to be fixed shall be final and binding on the contractor.
- d) If the whole or any part of the store supplied are rejected in accordance with Clause No.8 (c) above, the Purchaser shall be at the liberty, with or without notice to the Contractor, to purchase in the open market at the expenses of the Contractor, stores meeting the necessary performance and quality contracted for in place of these rejected, provided that either the purchase, or the agreement to purchase, from another supplier is made within six months from the date of rejection of the stores as aforesaid.

9. REJECTION OF STORES:

Rejected Stores will remain at the destination at the Contractor's risk and responsibility, if instructions for their disposal are not received from the Contractor within a period of 14 days from the date of receipt of the advice or rejection, the Purchaser or his representative has, at his discretion the right to scrap or seal or consign the rejected stores to the Contractor's address at the Contractor's entire risk and expense, freight being payable by the Contractor at actuals.

10. DELIVERY PERIOD:

- a) The delivery period of the stores stipulated in the Purchase order shall be deemed to be the essence of the Contract, and delivery must be completed on or before the specified dates/period.
- b) Should the Contractor fails to deliver the stores or any consignment thereof within the period prescribed for such delivery, the Purchaser shall be entitled at his option either.
 - i) to recover from the Contractor as agreed liquidated damages and not by way of penalty, a sum of 2% of the price of any stores which the contractor has failed to deliver as aforesaid for each month or part of a month, during which the delivery of such stores may in arrears, or
 - ii) to purchase elsewhere, without notice to the Contractor on the account and at the risk of the contractor, the stores not delivered or others of similar description (where other exactly complying with the particulars are not, in the opinion of the purchaser readily procurable, such opinion being final) without canceling the Contract in respect of the consignment(s) not yet due for delivery or,
 - iii) to cancel the contract or a portion thereof, and, if so desired to purchase or authorize the purchase of stores not so delivered or others of similar description (where others exactly complying with the particulars are not, in the opinion of the purchaser readily procurable, such opinion final) at the risk and cost of the Contractor.

In the event of action being taken under sub-clause (ii) and (iii) of clause 10 above, the Contractor shall be liable for any loss which the Purchaser may sustain on that account, provided that the re-purchase, or, if there is an agreement to re-provide shall made within (6) six months from the date of such failure. But the Contractor shall not be entitled to any gain on such re-purchase made against default. It shall not be necessary for the purchaser to serve a notice of such re-purchase on the defaulting Contractor. This right shall without prejudice to the right of the purchase to recover damages for breach of contract by the Contractor.

11. EXTENTION OF DELIVERY TIME:

As soon as it is apparent that Contractor delivery period / dates cannot be adhered to, an application shall be sent by the Contractor to the Purchaser. If failure, on the part of the Contractor to deliver the stores in proper time shall have arisen from any cause which the Purchaser may admit as reasonable ground for an extension of the time (and his decision shall be final he may allow such additional time as he considers it to be justified by the circumstances of the case without prejudice to the Purchaser's rights to recover liquidated damages under clause 10(i)(ii) and (iii).

12. PAYMENT:

Contractor's Bill will be passed only after the stores have been received, inspected and accepted by the Purchaser for payment.

13. RECOVERY OF SUMS DUE:

Whenever there is a breach of contract whether liquidated or not, money arising out of or under this contract against the contract, the Purchaser shall be entitled to recover such sum by appropriating, in part or whole, the security deposited by the Contractor, if a Security is taken against the contract. In the event of the Security being insufficient or if no security has been taken from the Contractor, then the balance or the total sum recoverable as the case may be shall be deducted from any sum then due or which at any time thereafter may become due to the contractor under this or any other contract with the Purchaser. Should this sum be not sufficient to cover the full amount recoverable, the Contractor shall pay to the Purchaser on demand the remaining balance due. Similarly, if the purchaser has or makes any claims, whether liquidated or not, against the Contractor under any other contract with the purchaser, the payment of all moneys payable under the contract to the Contractor including the Security Deposit shall be withheld till such claims of the Purchaser are finally adjudicated upon and paid by the Contractor.

14. INDEMNITY:

The Contractor shall warrant and be deemed to have warranted that all stores supplied against this contract are free and clean of infringement of any patent, copy right or trade mark, and shall at all time indemnify the purchaser against all claims which may be made in respect of the stores for infringement of any right protected by patent, registration of design or trade mark and shall take all risk of accidents of damage which may cause a failure of the supply from whatever cause arising and the entire responsibility for sufficiency of all the means used by him for the fulfillment of contract

15. ARBITRATION:

In the event of any question, dispute or difference arising under these conditions contained in the purchase order in connection with this contract, (except as to any matters the decision of which is specially provided for by these conditions), the same shall be referred to the sole arbitration of the Head of the Institution or of some other person appointed by him. It will be no objection that the arbitrator is a Government Servant, that he has to deal with matter to which the Contract relates or that in the course of his duties as Government Servant he has expressed views on all or any of the matters in dispute binding on the parties of this Contract.

(a) IT IS TERMS OF THIS CONTRACT:

If the Arbitrator be the Head of the Institution.,

i) in the event of his being transferred or vacating his office by resignation or otherwise, it shall be lawful for his successor-in-office either to proceed with the reference himself, or to appoint another person as arbitrator, or,

ii) in the event of his being unwilling or unable to act for any reason, it shall be lawful for the Head of the Institution, to appoint another person as arbitrator or,

(b) If the Arbitrator be a Person appointed by the Head of the Institution :-

In the event of his death, neglecting or refusing to act, or resigning or being unable to act for any reason, it shall be lawful for the Head of the Institution either to proceed with reference himself or to appoint another person as arbitrator in place of the outgoing arbitrator. Subject as aforesaid, the Arbitration Act, 1940 and the rules there under and any statutory modifications thereof for the time being in force shall be deemed to apply to the arbitration proceedings under this clause. The Arbitrator shall have the power to extend with the consent of the Purchaser and the Contractor the time for making a publishing the award. The venue of Arbitration shall be the place as the Purchaser. In his absolute discretion may determine. Work under the contract shall if reasonably possible, continue during Arbitration proceedings.

16. COUNTER TERMS AND CONDITIONS OF SUPPLIERS:

Where Counter Terms and Conditions/printed or cyclostyled conditions have been offered by the Supplier, the same shall not be deemed to have been accepted by the Purchaser, unless specific written acceptance thereof is obtained.

17. SECURITY FOR PURCHASER'S MATERIAL(S):

Successful Tenderer will have to furnish in the form of a Bank Guarantee or any other form as called for by the Purchaser towards adequate security for the materials/property provided by the Purchaser for the due execution of the Contract.