

INDIAN INSTITUTE OF ASTROPHYSICS

2nd BLOCK, KORAMANGALA, SARJAPUR ROAD,

BANGALURU – 560034.

TENDER DOCUMENT

***Name of Work:* Construction of Staff accommodation at I.A.O, Hanle,
Leh-ladakh**

Tender Notice No.: 03 /IIA/CIVIL/IAO-HANLE/ACCOM/ 2015-16 Dated 14.08.2015

INDIAN INSTITUTE OF ASTROPHYSICS

Ph.080-2554 1200/1259/1359 , **Fax:** 25534043

Website: www.iiap.res.in, **E-mail:** astron@iiap.res.in



INDIAN INSTITUTE OF ASTROPHYSICS

2ND BLOCK, KORAMANGALA, SARJAPUR ROAD, BANGALORE-560 034

Tender Notice No.: 03 /IIA/CIVIL/IAO-HANLE/ACCOM/ 2015-16 Dated 14.08.2015

The Director, Indian Institute of Astrophysics invites sealed item rate tenders in the prescribed form for the following work from appropriate registered contractors in state PWD, CPWD, MES, Scientific institutions and private body contractors who have executed works of similar nature.

Sl. No.	Name of the work	Estimated cost in Rs.	Time for completion	EMD Rs.	Cost of tender document Rs.
1.	Construction of Staff accommodation at I.A.O, Hanle, Leh-ladakh	29.00 Lakhs	12 Months	60000.00	500=00

The Tender Document can be viewed and downloaded from our website www.iiap.res.in/tenders.htm. The interested tenderers may at their option download the same, as **“NO” hard copies of Tender document shall be provided from this office** and submit their offers along with EMD (refundable) & Tender fee (non-refundable) prescribed therein, only in the form of Demand Draft drawn in favour of **Director, Indian Institute of Astrophysics, Bangalore.**

The Offers containing complete tender document duly filled with price (Bill of Quantities) and complete credentials including experience certificates should be submitted in sealed cover superscribing the envelope with **“Construction of Staff accommodation at I.A.O, Hanle, Leh-ladakh”**, Notice No. and due date”, shall be submitted addressed to The Director, Indian Institute of Astrophysics, 2nd Block, Koramangala, Bangalore– 560 034. **The last date of submission of bid is 04.09.2015 on or before 3:00 pm.** The bids will be opened at **3.30 pm.** on the same day in the presence of attending tenderers or their authorized representatives.

2. The firms who fulfill the following requirements shall be eligible to submit their Bids. Joint ventures are not acceptable.

(i) Tendering Company shall be professionally managed and resourceful for taking up similar jobs.

(ii) Tenderer should have completed atleast one similar single work for a minimum value of

Rs.30.00 lakhs or two similar works of minimum value of Rs. 20.00 lakhs in the last 5 financial years (i.e., current year and four previous financial years)

(iii) The tenderer should have executed similar construction of solar passive buildings.

3. Technical & price Bids supported by the above information should be submitted in a Sealed envelope duly superscribed with the name of work, tender notice No., Last date of submission. The completed Bids will be received by this office upto 15:00 Hrs. on **04.09.2015**
4. If any information furnished by the tenderers is found incorrect at a later stage, the firm shall be liable to be debarred from tendering and taking up of work in I.I.A. The Institute reserves the right to verify the particulars furnished by the tenderers.
5. The firms should submit their offers along with EMD/Tender fee of prescribed amount upto **15:00 Hrs. Latest by 04.09.2015.**
6. Incomplete Technical Bids are liable for rejection.
7. Late & / delayed offer will not be considered.
8. IIA is not responsible for any delay / loss of documents in transit.
9. The Tenders will be opened **on in 04.09.2015 at 15:30** hours at **I.I.A, Bangalore** in the presence of bidders or their authorized representatives. The representatives of the tenderers should bring authorization letter / identification while attending for opening of the tenders.
10. IIA reserves the right to reject any or all tenders without assigning any reasons.

Administrative Officer
IIA, Bangalore-34.

INDIAN INSTITUTE OF ASTROPHYSICS

2nd Block, Koramangala, Bangalore-560 034

Tender Notice No.: 03 /IIA/CIVIL/IAO-HANLE/ACCOM/ 2015-16 Dated .14.08.2015

M/s.

Dear Sirs,

The Director, Indian Institute of Astrophysics, Bangalore invites Sealed Tenders for the work of **“Construction of Staff accommodation at I.A.O, Hanle, Leh-ladakh”**. The Tender Terms enclosed herewith may be noted carefully. If you are in a position to quote for the work in accordance with the requirement, please submit your quotation in the attached Tender Form.

Your Tender must reach this office on or before the date and time indicated in the Tender Schedule.

Thanking you,

Yours faithfully,

(P.Kumaresan)

Encl: as above.

Administrative Officer

For Director

3. INSTRUCTIONS TO THE TENDERERS

1. The tenderers should submit the entire tender document with duly filled with price and technical details of the firm. All the pages of document shall be duly signed.
2. The Offers should be submitted in sealed envelope super scribed with “Tender for **“Construction of Staff accommodation at I.A.O, Hanle Leh-ladakh”**., Notice No. and due date”.
3. If any clarification is required should be obtained before filling Tender Document.
4. If any discrepancy is there between figures and words for quoted rates, the lower of the two will be considered for the purpose of evaluation.
5. The tenderers who do not fulfill all or any of the tender conditions or if the tender is Incomplete in any respect, will be summarily rejected.
6. The Institute is not bound to accept the lowest tender.
7. Even though the Tenderers meet the above criteria, they are subject to be disqualified if they have (The Institute reserves the right to verify the particulars furnished by the tenderers.)
 - Made misleading or false representations in the forms, statements and attachments submitted in proof of the qualification requirement, Conditional bid / proposal: and / or
 - Record of poor performance such as abandoning the works, not properly completing the contract, inordinate delays in completion, litigation history, or financial failures etc.
8. Any effort by the contractor to influence the client in the bid evaluation, bid comparison or contract award decision results in rejection of the contractors bid.
9. Incomplete Technical Bids are liable for rejection. Commercial/price bids will be Considered for opening only for the Qualified Technical Bidders, which are recommended by the Technical evaluation committees being constituted for the purpose.
10. Late & / delayed offer will not be considered at all.
11. IIA is not responsible for any delay / loss of documents in transit.
12. No bids will be considered if prescribed Tender Fee and EMD is not found with the bid.
13. All overwriting and corrections shall be duly attested with stamp & signature.

14. Corrigendum's / modifications / corrections, if any, will be published in the website only.
15. The Director, Indian Institute of Astrophysics reserves the right to accept or reject the tenders in full or part without assigning any reason thereof.
16. Performance certificates of the completed works issued by the clients to be enclosed in the technical bid.
17. The committee constituted by the director may inspect the previously completed or the ongoing works of the bidders to assess their technical suitability for the tendered work.
18. All the pages of the tender document to be signed by the contractor and submit them in the respective sealed covers.
19. **All the bidders are requested to visit the site before quoting the rates. The complete document shall be read and understood in all respect. If any clarification is required, the same may got cleared before submitting their offers in writing.**

**INDIAN INSTITUTE OF ASTROPHYSICS
2ND BLOCK, KORAMANGALA, SARJAPUR ROAD,
BANGALORE – 560034.**

Name of Work: “Construction of Staff accommodation at I.A.O, Hanle,
Leh-ladakh”

Tender Notice No.: 03 /IIA/CIVIL/IAO-HANLE/ACCOM/ 2015-16 Dated .14.08.2015

Name of

The Firm: _____

Address: _____

Phone No: _____

Last date for submission: 04.09.015 up to 3:00 PM.

FORMAT FOR SUBMISSION OF TECHNICAL & ORGANISATIONAL DETAILS.

NAME OF THE FIRM :

1. OFFICE SET UP OF THE FIRM

1.1 Office Address :

.....

.....

1.2 Year of Establishment :

1.3 Contact Person Shri.....

With Designation

Ph No.....

Fax No.....

E-mail.....

1.4 Details of registration if any:

.....

1.5 Organizational setup of the firm

Total staff strength both technical

and Administration with their name, age

qualification and experience :

1.6 PAN (photocopy to be enclosed)

1.7 Details of the staff as per the following format.

Sl. No	Profession/discipline	Name	Age	Qualification	Experience (total years)	Field of experience
	Civil					
	Electrical					

2 TENDERER'S EXPERIENCE

Details of Works carried out and on hand during last five years with details such as name of work, year of completion, client name and address, cost of work, time period of construction, nature of work, etc., (It shall enclose a certificate from the owner that the service rendered by the firm has been satisfactory)

Sl. No.	Name & description of work	Value of work and date.	Period of construction and date.	Client persons to whom reference may be made.

3.

TOOLS AND EQUIPMENT LIST

The tenderer shall indicate herein below the equipment he has in possession and the equipment he proposes to bring to the site, in case the work is awarded to him.

Sl. No	Type and Description of the equipment.	Numbers the bidder has in possession	Numbers he proposes to bring on to site

Tenderers hereby confirms that the quantity and type of tools he will employ for construction will not be less than those listed above and agree to bring more equipment if so warranted in the opinion of the Engineer-in-charge.

4. FINANCIAL

Bank Name: _____

Branch: _____

Account No.: _____

Average Annual Turnover for last 5 Years: _____

6. INSURANCE

Accident Insurance

Insured with: _____

Policy No.: _____

7. Details of Arbitration cases : í í í í í í í í í í í í í í í í

8. Any other detail you would like to intimate in support of your technical bid for appointment : í í í í í í í í í í í í í í í í

Signature of the authorized
Person with seal of the firm

(Note: Attach separate sheet for furnishing information in case the space in the format is insufficient)

**INDIAN INSTITUTE OF ASTROPHYSICS
2ND BLOCK, KORAMANGALA, SARJAPUR ROAD,
BANGALORE – 560034.**

PRICE BID

Name of Work: "Construction of Staff accommodation at I.A.O, Hanle, Leh-ladakh"

Tender Notice No.: 03 /IIA/CIVIL/IAO-HANLE/ACCOM/ 2015-16 Dated 14.08.2015

Name of

The Firm: _____

Address: _____

Phone No: _____

Last date for submission: 04.09.2015 @ 3.00 P.M

Tender for the “Construction of Staff accommodation at I.A.O, Hanle, Leh-ladakh”

Conditions of contract.

Sealed item rate tenders are invited by Indian institute of Astrophysics for the above mentioned work

Estimated cost : Rs 29.00 Lakhs (Twenty-nine lakhs only)

Time of completion : **Twelve (12) Months.**

Period of commencement : 7 days from the date of receipt of work order

Percentage of retention money: : 5% to be deducted from each RA bill and shall be released as under i)(50% on completion of works and along the final bill .ii) Balance 50% less recovery, if any towards the cost of defects rectified by employer due to lack of response of the contractor on completion of defects liability period and on certification by the engineer in charge.

Defects liability period : 12 Months.

Amount of liquidated damage : 1% (one percent) per week subjected to the maximum of 10% of the value of contract.

Escalation : In view of the short duration of the contract, no escalation will be paid to the contractor on account of changes in the market prices of any items of work or changes in the cost of living indices etc.

The Director, Indian institute of Astrophysics reserves the right to reject any or all the tenders without assigning any reason whatsoever.

The tenderer shall be responsible for arranging and maintaining at his own cost all **materials, tools and plants, water, electricity, facilities for workers, safety norms** and all other services required for executing the work.

Timely completion of work and quality of workmanship are of prime importance and the work shall be completed within the stipulated period. Cement consumption must match with standard theoretical calculations. Recovery to be effected in the event of not fulfilling the cement consumption. The waterproofing is the main work for which five year performance guarantee need to be provided by the applicator.

I/ We have read the tender notice, specifications, schedule, drawings, general rules and all other contents of the tender conditions, and Understand that you are not bound to accept the lowest or any tender you may receive.

I/ we hereby tender for the execution for the work specified above within the time specified above, at the rates specified in the attached bill of quantities and in all respects with these specifications, design, drawings and instructions.

I/we agree that should I/we fail to commence the work specified in the above memorandum an amount equal to amount of earnest money mentioned in the form of invitation of tender shall be absolutely forfeited to the Director.

Dated: -----

Signature of the contractor With stamp

General conditions of contract.

Item rate tender for works.

- ❑ The institute reserves the right to alter the scope /or reduce quantum of work before issue of work order and the contractor shall not have any claim what so ever on this account.
- ❑ Rates quoted by the contractor in item rate tender in figures and words shall be accurately filled in so that there is no discrepancy in the rates written in figures and words. However if a discrepancy is found, the rates which correspond with the amount worked out by the contractor shall be taken as correct.
- ❑ If the amount of an item is not worked out by the contractor or it does not correspond with the rate written either in figures or words, then the rate quoted by the contractor in the words shall be taken as correct.
- ❑ When the rates quoted by the contractor in figures and in words tally but the amount is not worked out correctly the rate quoted by the contractor will be taken as correct and not the amount.
- ❑ The contractor shall take all precautionary measures to prevent entry of dust, dirt and noise pollution to the adjacent buildings and keep the premises neat and tidy, remove surplus materials and rubbish and shall not cause inconvenience to the staff of IIA. If the contractor or his working people or servants shall break, deface, injure or destroy any part of a building in which they may be working or any buildings, road, kerbs, fence, enclosure, water pipes cables, drains, electric and telephone posts or wire, trees grass or garden. The cost of any such damage and risks arising out of this shall be entirely borne by the contractor.
- ❑ A bill shall be submitted by the contractor each month on or before the date fixed by the Engineer- in charge. All the measurements of the work may be recorded jointly by the Engineer-in charge and the contractor or their respective representatives. The measurements will be taken at site, as per latest IS code of practice for measurements. All measurements shall be taken with steel tapes only.
- ❑ The Engineer- in -Charge shall have full powers to the removal from the premises of all materials and bad workmanship, which in his opinion are not in accordance with the specifications.

- The Engineer in- Charge may require the contractor to dismiss or remove from the site of the work any person or persons in the contractors employ upon the work who may be incompetent or misconduct himself.
- For working on Sundays, holidays and late hours prior permission will be accorded by the Engineer-in charge on the application made by the contractor.
- All works to be executed under the contract shall be executed under the direction and subject to the approval in all respects of the Engineer-in charge who shall be entitled to direct at what point or points and in what manner they are to be commenced and from time to time carried on.
- The contractor shall treat all materials obtained during dismantling of a structure, excavation of the site for a work etc as institute's property and such materials shall be disposed off to the best advantage of the institute.
- The contractor shall execute the whole and every part of the work in the most substantial and workman like manner and in strict accordance with the specifications of the CPWD / DOS / Bureau of Indian Standards. In case of any class of work for which there is no such specifications the contractor shall carry out the work in all respects in accordance with the instructions in writing of the Engineer- in charge.
- The Engineer-in charge shall have powers to make any alterations in, omissions from, additions to or substitutions for the original specifications, drawings, designs and instructions that may appear to him necessary or advisable during the progress of the work and the contractor shall carry out the work in accordance. The rates for such additional, altered or substituted items of work shall be worked out in accordance with the standard procedure followed in CPWD / DOS.
- If at any time after the commencement of the work, the director shall for any reason whatsoever not require the whole thereof as specified in the tender to be carried out, the Engineer- in-Charge shall give notice in writing of the fact to the contractor who shall have no claim to payment of compensation whatsoever on account of any profit or advantage which he might have derived from the execution of the work in full, but which he did not derive in consequence of the full amount of the work not having been carried out, neither shall he have any claim for compensation by reason of any alterations having been made in the original specifications , drawings ,designs and instructions which shall involve any curtailment of the work as originally contemplated.

- The contractor shall obtain a valid license under the Contract Labour (R&A) act 1970 and the contract labour (Regulation & Abolition) central rules, 1971 before the commencement of the work and continue to have a valid license until the completion of the work. No labour below the age of eighteen years shall be employed on the work. The contractor shall pay to labour employed by him either directly or through sub contractors, wages not less than fair wages as defined in the provision of the contract labour (R&A) act 1970 and the contract labour (R&A) central rules 1971 wherever applicable.

- The contractor shall at his own expenses arrange for the safety provision as per safety code framed from time to time and shall at his own expenses provide for all facilities in connection therewith.

- The contractor shall comply with all the provisions of the payment of wages act 1936, Minimum Wages Act 1948, Employees liability act 1938, Workmen's Compensation act 1923, Industrial Disputes Act 1961 and the Contractors Labour (R&A) Act 1970 or the modifications thereof or any other laws relating thereto and the rules made thereunder from time to time. The regulations aforesaid shall be deemed to be a part of this contract and any breach thereof shall be deemed to be a breach of this contract. Security deposit will not be refunded till clearance certificate from Labour Officer is obtained by contractor.

- The contractor shall make his /their own arrangements for water required for the works and nothing extra will be paid for the same, as the water available from the institute source may not be sufficient to meet the construction.

- The contractor shall have all the tools and plants necessary to carry out the work such as concrete mixer, vibrator and hoist. The contractor shall employ one graduate engineer during the execution of the work

- Certified plumbers should be employed by the contractor on the plumbing and sanitary work.

- The standard sectional weights referred to as standard tables in para 5.3.3 in CPWD specifications for works 1977 vol. 1 to be considered for conversion of length of various sizes of M.S bars and tor steel bars in to weight.

Size (diameter MM) Weight Kg/M

Size (mm)	Weight (Kg/m)
6	0.222
8	0.395
10	0.617
12	0.888
16	1.579
18	1.999
20	2.467
22	2.985
25	3.855
28	4.836
32	6.316

- The entire work is to be completed within the period stipulated i.e. **Twelve (12) months** from the 7th day of issue of Letter of Intent/Work Order. The period includes monsoon period also. Time shall be the essence of the contract. After the work awarded, the contractors shall furnish detailed time schedules for the approval of the Engineer-in charge which after approval shall form part of the contract and are to be strictly adhere to.

- The maintenance period for the work shall be twelve (12) months and any defects noticed during the period shall have to be rectified by contractor at his cost, failing which the action taken for maintenance Engineer-in charge shall be final over which the contractor will not have any claim.

- The contractor shall extend all co-operation to the contractors executing works such as electrical, air conditioning etc who might be working at the site and shall permit to use scaffolding etc already put up by him.

- The Engineer-in charge will have the right to get any item of the work included in this tender or not executed through other agencies. Schedule of probable quantities in respect of the work and specifications are enclosed. The schedules of probable quantities are liable to alterations by emission, deduction or additions at the discretion of the Engineer-in charge.

- The rates quoted by the tenderer in the schedule shall be inclusive of all taxes and levies payable under respective statues, inclusive of all sales taxes, sales tax on components/ materials/ consumables and also sales tax on works contract in pursuant to constitution (forty sixth amendment) act 1982, control duty and /or any other duty levied by the government or other public bodies. The rates shall be firm and shall not be subject to exchange variations, labour conditions or any condition.

- Sales tax will be deducted from the amount payable to the contractor as per the relevant sales tax act, applicable for the contracted work as amended from time to time, at the rates specified from time to time.

- Samples of all materials to be incorporated in the works shall be submitted to the Engineer-in charge for his approval without claiming any extra cost. Materials not confirming strictly to the samples are liable to be rejected.

- The employment of any sub-contractors will be subjected to the approval of the Engineer-in-charge. If at any time during the progress of the work the Engineer-in charge determines that any sub-contractor is in competent or undesirable the contractor shall take steps immediately to cancel such sub-contractor. The contractor shall be entirely responsible for all the work included in the contract whether executed by him or through his sub-contractors. In particular it may be noted that the contractor shall obtain steel doors and windows from a reputed manufacturer and before placing order for these, the contractor shall obtain the concurrence of the department for the agency from whom he proposes to obtain steel doors and windows.

- The contractor shall prepare a CPM / PERT /BAR chart/ Detailed estimate programme within a weeks time of issue of Work Order.

- All materials and articles brought by the contractor to the work site shall have to be declared at the security gate. Similarly no materials shall be taken out from the departmental premises without proper gate pass which will be issued by the Engineer-in charge.

- Unless otherwise provided in the schedule of quantities the rates tendered by the contractor shall be all inclusive and shall apply to all heights, lifts, leads and depths of the building and nothing extra shall be payable to him on this account.

- Sample of various materials required for testing shall be provided free of charge by the contractor. Testing charges, if any unless otherwise provided, shall be borne by the department. All other expenditure required to be incurred for taking the samples, conveyance, packing etc. shall be borne by contractor himself. In case of concrete and reinforced concrete work, the contractor shall be required to make arrangement for carrying out compression strength tests at his own cost including preparation of cubes curing etc. complete.
- For the purpose of recording measurements and preparing running account bills, the abbreviated nomenclature shall be accepted along with the item number.
- The contractor shall along the tender submit a schedule of machinery to be used on the work in support of his assurance to adhere to the time schedule specified in the proforma given.
- I /We declare that the work will be carried out as per the specifications in tender document and as per the specifications said above. The items of work not covered in the specifications said above will be carried out as per the specifications in the relevant CPWD specifications, and if not covered in CPWD specifications the work will be carried out as in the relevant IS specifications, and if not covered in the any of the above, the work will be carried out as directed in writing by the Engineer- in charge.
- I / We declare that the rates quoted by me/us are on the basis of the above.

Dated: -----

Signature of the contractor With stamp

TENDER FORM

To,

The Director,
Indian institute of Astrophysics,
Koramangala,
Bangalore - 560034

Dear Sir,

Sub: Tender for project : “Construction of Staff accommodation at I.A.O, Hanle Leh-ladakh”

With reference to the tender invited by you for the above proposed work, I /we write this after having:

- a). Examined the designs, drawings, detailed specifications to tenders, sample agreement, the general conditions of contract and special conditions of contract annexed there to (here in after called the contract documents) relating to construction.
- b). Visited and examined the site of the proposed work and acquired the requisite information relating to or affecting the tender. We are agreed to the decisions of the pre bid meeting by signing and stamping the minutes of the meeting which is enclosed along with this tender.

I/We undersigned hereby offer to construct the proposed work in strict accordance with the contract document for the consideration to be calculated in terms of the priced schedule of quantities.

I/We undertake to complete the whole of the works as per the attached schedule from the date of issue of intimation by you that our tender has been accepted and up on being permitted to enter site. I/We further undertake that on failure, subject to the conditions of contract relating to extension of time, I/We shall be agreed Liquidated damages for the period during which the work shall remain incomplete.

I/We hereby deposit with you as earnest money **Rs..... (RUPEES**
.....ONLY) [Carrying no interest]
and I/We fail to take up the contract when called up on to do so.

Our Bankers are

1.

2.

Place:

Date:

Signature of the tenderer

Name of the partners of the firm

Or

Name of the person having power of attorney to sign the contract

SPECIAL CONDITIONS

GENERAL:

SPECIAL CONDITIONS OF CONTRACT shall be read in conjunction with GENERAL CONDITIONS OF CONTRACT and both form an integral part of contract. Where the two are at variance, the conditions stipulated in this as SPECIAL CONDITIONS shall supersede relevant GENERAL CONDITIONS.

1. SPECIAL CONDITIONS:

HELMETS :

As a measure of safety, persons employed on the site, Engineers and Supervisors shall wear a helmet of approved make at all times when they are at the site. No visitors shall be allowed on work site without wearing helmet.

Contractors shall make arrangements to provide safety helmets to all the persons employed on the site, Engineers and Supervisors at his cost.

Contractors shall display safety and warning signs at strategic locations at the site.

CHILD LABOUR:

Contractor or his Sub-contractor shall not employ any child labourers on the work site, either permanently or temporarily. It shall be the responsibility of the main Contractor to make sure that no child labour is employed at the site. Contractor shall indemnify the Employer against any consequences statutory or otherwise, that may arise out of employing child labour on the site.

TEMPORARY ELECTRICAL WIRING:

It shall be the responsibility of the main Contractor to make sure that the temporary wiring for construction activity shall adhere to minimum safety precautions as per Electricity Act. All wires / cables shall be drawn on wooden poles properly fixed and shall be drawn overhead.

2. LABOUR SHEDS:

Labour sheds shall be constructed with non-combustible materials like GI sheets or Asbestos sheets. Contractor will not be permitted to use combustible materials such as palm leaves etc., for the construction of the labour sheds.

3. MATERIALS SUPPLY / PROCUREMENT:

No materials will be supplied by the owner. If any increase on the material procurement cost/ labour, P&M will not be entertained for any kind of escalation till completion of the project.

4. BILLING. CERTIFICATION & PAYMENT OF BILLS:

BILLING:

The contractor shall prepare measured bills after completing the quantum of work mentioned In the Appendix-A and submit the same to the Architects for checking and issue of Certificates for Payment.

PAYMENT OF BILLS:

The contractor shall be paid by the Employer from time to time based on the certificate for payment issued by the architects as mentioned in the Appendix A.

5. REPAIR OF WORKS DONE BY OTHER AGENCIES:

The civil contractor shall make up any deficiency in the finishing of the areas damaged by other agencies in a workmanlike manner to achieve uniform finishing of the building at no extra cost.

6. MATERIAL TESTS:

The contractor shall provide such assistance, instruments, machines, labour and materials as are normally required for examining, measuring and testing.

The contractor shall install a compression testing machine at site to test concrete cubes and solid blocks.

The contractor shall maintain a record of all the test results in an approved format and periodically submit the same for Architect's/Employer's scrutiny.

7. PLANT & MACHINERY:

The contractor is obliged to furnish to the Employer detailed list of equipment, plant, machinery & personnel proposed to be deployed in this project.

8. CLIENT'S & ARCHITECT'S OFFICES & FACILITIES:

The contractor shall supply, erect and satisfactorily maintain in good repair until final completion of works, a well lighted temporary site office.

The contractor shall provide at all times for the duration of the contract survey instruments for the exclusive use of consultants as directed by consultants for carrying out of his duties in connection with the contract.

Such instruments which must be approved by the Architect, shall include but not limited to the following:

- One theodolite & tripod capable of reading to 20 seconds
- One level with horizontal circle and tripod.
- Two metric leveling staffs not less than 3.5mtr high.
- One 100 metre rustless steel band, one 30 metre rustless steel tape and two 30 metre linen tapes.

- An adequate number of ranging rods drop arrows, wooden setting-out pegs, etc.

The contractor shall be solely responsible for all such instruments and equipment's and shall ensure that they are at all times in good repair and adjustment.

10. SANITATION & DRAINAGE DURING CONSTRUCTION:

The contractor shall provide sanitation and drainage facilities on the site as stated subsequently.

The contractor shall strictly control the labour so that the site is not polluted, made dirty or littered with debris, wastes or the likes. Any person found creating mess or litter or pollution shall be removed from the site immediately at contractor's cost.

The contractor shall provide sanitation facilities at convenient locations on site to preserve the cleanliness of the site. The effluent shall be directed as follows:

- Waste water : Collection and pumping out and disposal off the site in approved manner.
- Sewage : Septic tank provision - sludge to be collected and disposed off at intervals as directed.

The location of the above provisions shall be as marked on the site mobilization scheme drawing.

11. DISCREPANCIES:

The contractor shall bring to the notice of the Architect any discrepancies within or between contract drawings and/or the other contract documents prior to preparation of working drawings and commencement of work and shall not proceed with work until the Architect gives clarifications and instructions to proceed.

12. REPORTS BY CONTRACTOR:

- 12.1 The contractor shall file daily category-wise labour return. The report shall indicate scheduled requirement against actual strength.
- 12.2 The contractor shall prepare weekly reports of planned and actual progress of work and subsequent week's scheduled work. These will also include material procurement status. These reports shall be submitted to Architect and shall be reviewed during weekly co-ordination meeting.
- 12.3 The contractor shall submit monthly report along with monthly bills.
- 12.4 Further progress charts and schedules shall be prepared by the contractor as directed by the Architect.
- 12.5 The contractor shall submit re-conciliation statement of all the materials supplied by the Client, if any, alongwith every running & final bill.

LIST OF APPROVED MATERIALS

CIVIL

Sl. No.	Material	Make
1	Steel	SAIL – TMT, VIZAG STEEL
2	Cement	ACC/Birla/L&T
3	Acrylic Exterior Emulsion	Asian Paints
4	Plastic Emulsion Paint	Asian Paints
5	Enamel Paint	Asian Paints
6	Aluminium	Jindal, Indal, Hindalco
7	Glass	Saint Gobain, Modi
8	Flush Door	Kutty's Bond Wood, Hunsur Board
9	Vitrified tiles	nitco/RAK
10	Ceramic tiles	NITCO

WATER SUPPLY AND SANITARY WORKS

Sl.No.	Material	Make
1	PPR	Kisan/Amitex
2	UPVC	a) Kisan / Prince
3	Ball valves	Hawa / R.B.
4	G.M. non-return valves	Kirloskar/Zoloto
5	Sanitary ware	Hindware/approved equivalent
6	C.P. Fittings	Jaquar/approved equivalent
7	Bathroom accessories	Jaquar/approved equivalent
8	SFRC manhole frame and Covers	Southern Concrete Industries/approved equivalent
9	Kitchen sink	Nirali/ Approved Equivalent
10	Anchor bolts/pipe support system	Hilti / approved equivalent
11	CI Grating & MH frame & cover	NECO/ Approved equivalent

BILL OF QUANTITIES

Bill of Quantities for the work of “Construction of Staff accommodation at I.A.O, Hanle Leh-ladakh”

(NOTE: Rates shall be quoted after reading the complete Specifications along with the drawings attached)

Sl. No.	Description of work	Quantity	Unit	Rate in Words and figure (Rs.)	Amount (Rs.)
1	Earth work in excavation by mechanical means (Hydraulic excavator) / manual means in foundation trenches or drains (not exceeding 1.5 m in width or 10 sqm on plan), including dressing of sides and ramming of bottoms, lift upto 1.5 m, including getting out the excavated soil and disposal of surplus excavated soil as directed, within a lead of 50 m. All kinds of soil	125	Cum		
2	Filling available excavated earth (excluding rock) in trenches, plinth, sides of foundations etc. in layers not exceeding 20cm in depth, consolidating each deposited layer by ramming and watering, lead up to 50 m and lift upto 1.5 m.	40	Cum		
3	Random rubble masonry with hard stone in foundation and plinth including levelling up with cement concrete 1:6:12 (1 cement : 6 coarse sand : 12 graded stone aggregate 20 mm nominal size) upto plinth level with : Cement mortar 1:6 (1 cement : 6 coarse sand) (The price is inclusive of procuring stones and other materials, transportation with all leads and lifts)	80	Cum		

Sl. No.	Description of work	Quantity	Unit	Rate in Words and figure (Rs.)	Amount (Rs.)
4	<p>PLAIN CEMENT CONCRETE:- Providing and laying cement concrete using 40mm nominal size graded hard granite stone aggregate obtained from approved quarry including compaction, finishing top surface to level, curing but excluding cost of formwork, etc; complete as per specifications. Mix ratio specified is for (cement: coarse sand : graded stone aggregate In foundation and flooring: P.C.C 1: 4: 8</p>	25	Cum		
5	<p>Providing and laying in position Reinforced cement concrete (R.C.C 1:2:4) using graded hard granite stone aggregate of 20mm nominal size obtained from approved quarry including mechanical mixing, vibrating, compaction, finishing, curing, etc; complete all as per specifications but excluding the cost of form works and steel reinforcement.(Rate to include labour for keeping embedment if any, wherever required while casting). Mix ratio is specified is for (cement : coarse sand : graded stone aggregate) all works upto plinth. Including finishing the fresh concrete surface to give a smooth finished surface etc. complete. All necessary finishing shall be carried out as per the instruction of Engineer Incharge</p>	28	Cum		

Sl. No.	Description of work	Quantity	Unit	Rate in Words and figure (Rs.)	Amount (Rs.)
6	Providing rigid and water tight centering and shuttering using best quality of shuttering plywood, steel centering sheets with steel props, acrotubes etc., including strutting, propping, bracing, staging etc., complete for all RCC items fixed in position as required including labour for careful removal of formwork etc., complete all as per specifications at all heights. In horizontal/ vertical / slanting surfaces.				
6.1	Foundations, footings, beams, slabs, lintels, Bases of columns, mass concreting, floorings, rammed earth walling system etc.	150	Sqm		
7	Steel reinforcement for all R.C.C items including decoiling, cutting, hooking, bending, cranking, fabricating to required shape, placing in position and tying the system with soft drawn annealed binding wire of diameter not less than 1.00mm with 2 strands etc; complete all as per specifications at all heights (binding wires will not be measured for payment). With high yield strength deformed bars.	3500	Kg		

Sl. No.	Description of work	Quantity	Unit	Rate in Words and figure (Rs.)	Amount (Rs.)
8	Providing and constructing rammed earth wall (with Goe mesh for structural wall and thermal mass)of thickness 450mm to 600mm made out of soils containing 60 to 70% of sand and 10% of clay and 5% of cement pressed using suitable device for proper compaction. Including the cost of necessary shuttering etc.. complete	75	Cum		
9	Providing and constructing precast cement concrete block 1:3:6 masonry with 1:3 for thermal mass and heat bank in the building. Including filling the gap with necessary insulation material.	20	Cum		
10	Providing and fixing windows and door frames and window shutters made from FIR wood (excluding the cost of glass and hinges)	1.5	Cum		
11	Providing and fixing windows and door frames for bathroom doors made from DEODAR wood (excluding the cost of glass and hinges)	0.20	cum		
12	Providing and fixing shutters for doors made from 1st class FIR wood (excluding the cost of glass and hinges). Thickness of the plank shall be 25 mm and thickness of styles & rails shall be 40 mm. The rate shall be include for three coats of polish , labour and other material charges	16	sqm		

Sl. No.	Description of work	Quantity	Unit	Rate in Words and figure (Rs.)	Amount (Rs.)
13	Providing and fixing hardware like SS hinges, tower bolts, door locks etc complete for doors and windows including the cost of material and labour.	1	Lumpsum		
14	Providing and fixing 4mm thick branded double clear glass for window shutters with necessary putty and beadings etc. complete. including the cost of material and labour.	40	Sqm		
15	20 mm cement plaster 1:3 (1 cement: 3 coarse sand) finished with a floating coat of neat cement on the inside wall.	100	Sqm		
16	Providing and laying 450mm (18 inch) thick insulated flooring including necessary PVC sheet and 200 thick round river rock soling and 50 mm thick thermal mass including IPS flooring of 50 mm with glass strips as per standard specification.	40	Cum		
17	Internal painting with interior waterproof emulsion (Berger/Asian paints)	120	Sqm		
18	External painting with exterior emulsion with (Berger/Asian paints)	130	Sqm		
19	Enamel painting for wood in ceiling and doors & windows	100	Sqm		

Sl. No.	Description of work	Quantity	Unit	Rate in Words and figure (Rs.)	Amount (Rs.)
20	Providing and fixing 300mm thick insulated ladakhi traditional water proof roof with 1st class FIR (Budloo) wooden joists of size 75 mm X 175 mm in the roof bottom including the wastage etc complete. (The price shall include the cost of entire roof preparation including soil and all materials required to complete the job).	3.5	Cum		
21	Providing and fixing wooden planks made from popular 1st class FIR wood as per the design. including the wastage etc complete.(The price shall include the cost of entire roof preparation including soil and all materials required to complete the job).	3	Cum		
22	Local roof preparation including providing and filling with 6" soil and 2" stabilized mud etc. complete with necessary slope and drain. including necessary insulation. Including laying of Ladakhi traditional over hank on the roof including the cost of final cement works and painting.	15	cum		
23	Providing and laying Ladakhi Traditional over-hank on the roof and also included the cost of final cement works and painting:	14.43	Cum		
24	Roof Drain: Providing and fixing roof drain pipes of 100mm (4") dia to drain the rain and snow malting water of approved quality.	20	mts		

Sl. No.	Description of work	Quantity	Unit	Rate in Words and figure (Rs.)	Amount (Rs.)
25	Providing and laying of Jacket wall to pack the insulation between the jacket wall and Rammed earth wall:	36	Cum		
26	Providing and laying insulation on the roof: 15CM and also Providing and filling insulation (thermal material/sawdust) between the Jacket wall and Thermal Mass Rammed earth wall:	29	Cum		
27	Providing and fixing 6mm plywood for the false ceiling: including three coats of polish	31	Sqm		
28	Providing and laying of stabilized mud plaster outside of the building 20mm thick:	45	Sqm		
29	Tiles in the Bath Rooms and Bath Room materials: EWC, GI and CI Pipes, showers, western seat, mirror, Branded taps etc as per specification and instruction of the engineer complete bathroom fittings for all three toilets	1	L.S		
GRAND TOTAL				Rs.	

(Grand Total amount in words Rs.....)

.....

Date:

Signature of the contractor with seal

Place:

DRAWINGS

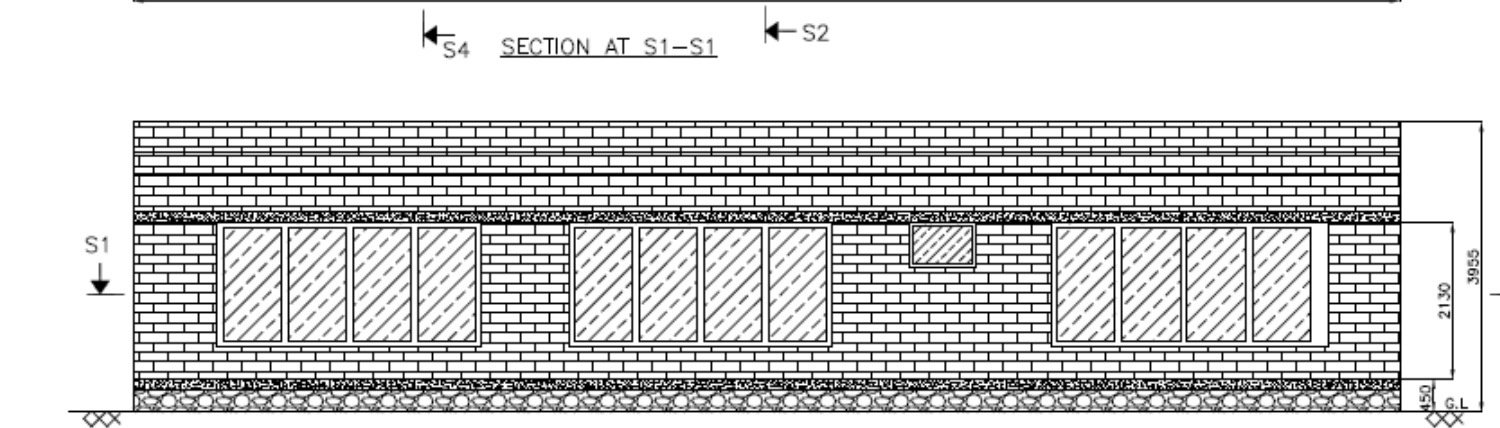
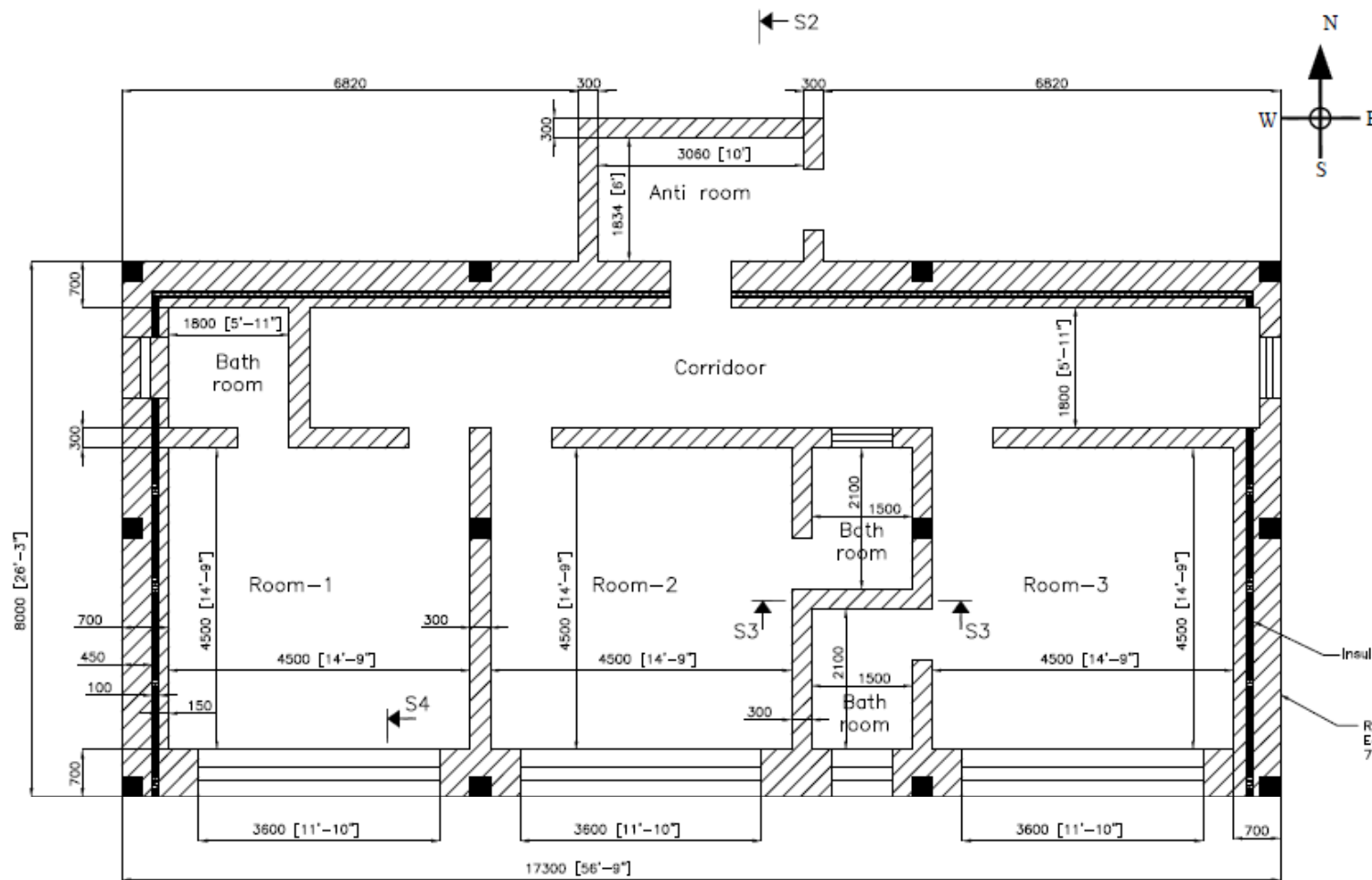

FRONT ELEVATION
(VIEW FROM SOUTH)

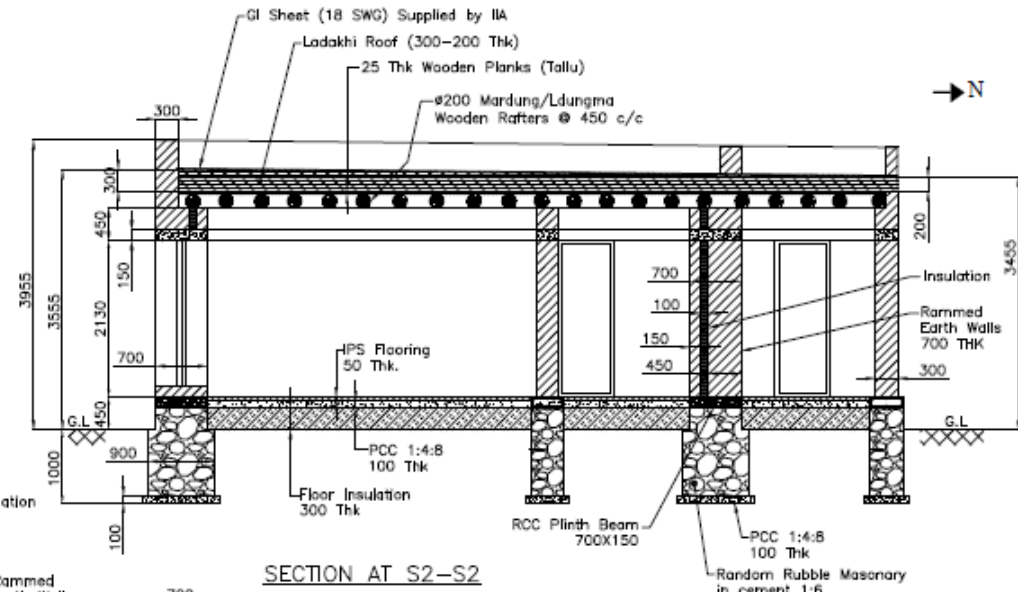
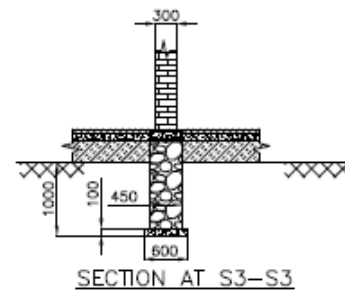

SECTION AT S2-S2

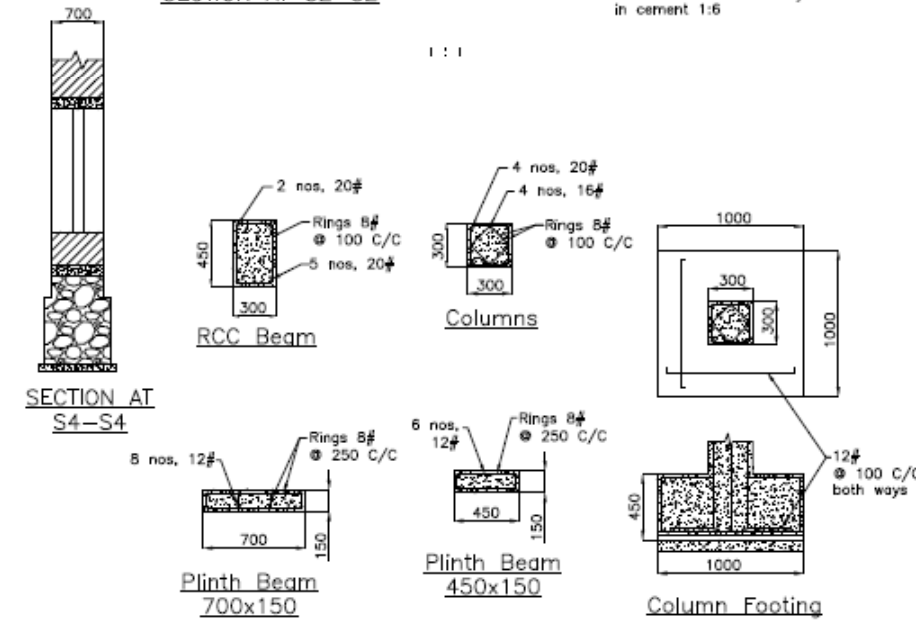

SECTION AT S4-S4

PROJECT: LEH	TITLE: PROPOSED STAFF ACCOMMODATION AT JAO HANLE
General Tolerance Shall be as per IS:2709-1964 unless otherwise specified	Scale: DR'N: V.K. Subramanian, 22/04/2015
All Dimensions are in "mm" unless otherwise specified	CH'D: APP'D:
 INDIAN INSTITUTE OF ASTROPHYSICS BANGALORE - 560 034 (Govt. of India, Ministry of Science & Technology)	DRG. No: -
	SHEET 01 OF 01
	Rev. RO Date: xx/xx/xx