



दूरभाष Ph : 91-80-25530672-76
फैक्स Fax : 91-80-25534043

भारतीय ताराभौतिकी संस्थान
INDIAN INSTITUTE OF ASTROPHYSICS
कोरमंगला / KORAMANGALA
बेंगलूर / BANGALORE - 560 034.

Deadline extended to May 16, 2008 15.00 Hrs

No: PUR/IMP/PUK/UVIT-ISO/100/07-08.

April 24, 2008

M/s .

Dear Sirs,

The Director, Indian Institute of Astrophysics, Bangalore invites Sealed **Tenders (both commercial bid and Technical bid)** for the Import of “ **Titanium forgings for satellite adapter as per the enclosed technical specifications (RPF) and drawings** ” detailed in the Tender Form hereto annexed. The terms and conditions are also enclosed may be noted and if you are in a position to quote for the supply in accordance with the requirement, please submit your quotation in the attached Tender Form. The Tender documents are available on IIA web site www.iiap.res.in/tenders.htm

The Tender bids should be in foreign currency only. Your completed Tender bids (both Commercial Bid and Technical bid) must reach this office in sealed separate envelopes duly superscribed with the name of the supply and due date on or before **15.00 Hrs. latest by 16.05.2008**. The Technical bids will be opened in presence of the bidders or authorized representatives at **15.30 Hrs. on 16.05.2008**. Incomplete Technical Bids are liable for rejection. Commercial/Price bids will be considered only for the qualified Technical Bidders.

Thanking you,

Yours faithfully,

Encl.: as above.

Administrative Officer
For Director



PUBLIC TENDER DOCUMENT NO: PUR/IMP/PUK/UVIT-ISO/100/07-08.
DT: 24.04.2008

TENDER FORM

FROM:

TO

THE DIRECTOR,
Indian Institute of Astrophysics.,
Bangalore-560 034.

Sir,

I/We hereby offer to supply the Items/Equipment indicated below at the price hereunder quoted and agree to hold this office open till _____. I/We shall be bound to supply the Items/Equipment hereby offered upon the issue of the Purchase Order communicating to the acceptance thereof on or before the expiry of the last mentioned date. You are at liberty to accept any one or more of the items of such Items/Equipment. I/We not withstanding that the offer in this tender has not been accepted in whole, shall be bound to supply such items and such portion or portions of one or more of the items as may be specified in the said Purchase Order communicating the acceptance.

Sl.No.	Description of the item(s)	Qty.	Unit	Rate	Dely. Period
1.	Titanium forging for satellite adapter as per the enclosed technical specifications (RPF) Annexure-I and drawing Annexure-II	2	Nos		

(All the drawings including 3D drawings are
Provided in electronic form)

**(Both Commercial and Technical bids must be submitted separately in a
Separate sealed envelopes)**

(Tender bids should be in Foreign currency only)



Place at which the Delivery is required : Indian Institute of Astrophysics
Bangalore-560034

Date by which the supplies are required : 4 weeks from the date of order

2. I/We have understood the items of the tender annexed to the invitation to the Tender and have thoroughly examined the specifications/drawing and /or pattern quoted or referred to herein and/are fully aware of the nature of the items/Equipment required and my/our offer is to supply the items/Equipment strictly in accordance with the requirements subject to the terms and conditions contained in the Purchase Order communicating the acceptance of this tender either in whole or in part.

Date:

Signature and Seal of Supplier

Annexure-I

Request For Proposals (RFP) **For the Supply of Titanium Forgings for Satellite Adapter.**

Introduction:

Indian Institute of Astro Physics (IIA) is developing an Ultraviolet Imaging Telescope (UVIT) system. In this connection we need Titanium alloy forgings meeting the following specifications. The forgings will go through further manufacturing processes at our end before they are assembled with the UVIT system and then with the Satellite. Since the forgings are used for making aerospace structural components, it is important that the product finally finish machined at our end, complies fully with the mechanical properties and other specifications given below.

Deliverables:

Two numbers of forgings manufactured and tested, conforming to the technical specifications mentioned below along with all the relevant test certificates and documentation.

Overall Requirements:

- 2D and 3D drawings of the baseline forging required are enclosed. The baseline drawings enclosed provide for 5 to 10 mm stock all over for finish machining at our end. The 3D drawing of the final product as it would appear, after the supplied forgings go through machining at our end, is also enclosed and it is to be used for information only.
- The forgings offered against this RFP shall enclose the envelope specified in these drawings as a minimum. Subject to meeting this requirement, the vendors are free to suitably modify / simplify the shape / sizes of the forgings actually offered by them in order to ensure that the total cost of the supply, including the material and dies / tooling costs, is kept at a minimum.
- The 2D drawings enclosed have been provided for a general reference. For finalizing the manufacturing drawing of the forging the vendors shall refer the 3D model supplied with this RFP.
- The forgings offered shall be single stock forgings without any welded joints.
- It is generally assumed that the hot forging as well as the annealing / heat treatment processes are done under inert / neutral environment. The vendors shall ensure that the forgings supplied are proof machined and no oxidation / contamination is left over, on the surfaces.
- Each forging after finish machining at our end is to be assembled with a precision fit with its mating part, with 0.020 mm to 0.040 mm radial clearance. As such the dimensional stability is a very important requirement. The vendors shall provide all the relevant information to support / prove that the forgings supplied would be dimensionally stable within +/- 0.010 mm over its major dimensions over a period of two years. Vendors shall recommend additional in-process heat treatments, if any, required to be implemented on the forgings, during the machining operations done at our end, in order to retain the dimensional stability.
- The vendors shall carefully consider and address all the above aspects and reflect them in their technical proposal. The technical proposal shall include the 2D and 3D drawings of the forgings actually being offered against this RFP, along with the overall process plan and product assurance plan.

Material specifications:

Material: Titanium Alloy Ti 6Al 4V, ASTM Grade 5, Annealed, Forgings conforming to ASTM B381-06a standard specifications or equivalent.

Composition:

Component	Wt. %
Al	6
Fe	0.25 max
O	0.20 max
Ti	90
V	4

Mechanical properties: (Minimum values)

Tensile strength, Ultimate	950 MPa.
Tensile strength, Yield	880 MPa.
Modulus of Elasticity	113.8 GPa
Compressive Yield Strength	970 MPa
Notched Tensile Strength	1450 MPa
Poisson's ratio	0.342
Fatigue Strength	510 MPa

Manufacture:

- Standard / proven processes shall be used for the manufacturing /forging. General guidelines shall be followed, like good handling practices, plant layout to minimize the number of reheats and minimizing the contamination during forging.
- The forgings shall be sized to provide for machining off the oxidized / contaminated stock, if any, completely as mentioned earlier.
- The forgings shall be sized to provide for the required test coupons also. This is done to ensure that the test coupons obtained have gone through exactly the same processes in the same sequence as that of the forging.
- Heat treatments for stress relieving, annealing, aging etc shall be carried out on the forgings as per standards and the details shall be provided in the technical offer.
- Product assurance and quality control practices shall be strictly followed and complete traceability of materials and processes shall be in place during the manufacture.

Testing / Inspection:

- All the raw materials used shall be screened 100 % to ensure that it is free from any defects /flaws. The forgings shall be proof machined and subjected to 100% X-ray and ultrasonic testing to AA class.
- Mechanical testing shall be carried out on coupons made from the forgings for checking the mechanical properties of the final forgings. One additional set of these coupons shall be supplied to IIA along with forgings for repeat checks, if required, as a contingency.
- Waivers if any, of all major non-conformances and deviations noted during manufacturing and testing shall be recorded and reported to IIA immediately on their occurrence along with the corrective plan / disposition. Only after a clearance from IIA, the vendor shall proceed with further processes.

Documentation:

- The following documentation and certifications shall be supplied along with the deliverables to show that the forgings supplied comply fully with the indent specifications / requirements.
- Summary of reports on raw material inspection, key information on processes and heat treatments.
- All test reports including the results of tests on test coupons, X- ray and ultrasonic tests, along with the metrology reports of the delivered products.
- Summary of non-conformances and their disposition reports generated during the manufacturing, processing, testing and evaluation phases.

General:

- The vendor shall provide the details of the overall process steps / plans proposed to realize the forgings in their proposal. The overall manufacturing drawings shall be given to IIA for approval before proceeding with manufacture.
- The offer shall be in two parts, put in separate sealed envelopes as given below.
- A) Technical offer with all technical details, delivery schedules etc.
B) Cost bid.



INSTRUCTIONS TO SUPPLIERS

1. Tenders should be sent in sealed and superscribed envelopes with mention of Tender No. date and date of opening. Only one Tender should be sent in each envelope.
2. Late and Delayed Tender will not considered at all.
3. Duties, Taxes where legally leviable and intended to be claimed should be distinctly shown separately in the Tender.
4. a) Your quotation should be valid for 90-120 days from the date. of opening of Tender
b) Prices are required to be quoted accordingly to the units indicated in the annexed tender form. When quotations are given in terms of units other than those specified in the tender form, relationship between the two sets of units must be furnished.
5. Preference will be given to those tenders offering supplies from ready stocks and on the basis of delivery at Site.
6. a) All available Technical Literature(s), Catalogue(s) and other data in support of the specifications and details of the item(s) should be furnished along with the offer.
b) Approximate net and gross weight of the items offered shall be indicated in your offer. If dimensional details are available the same should indicated in your offer.
c) Air freight/sea freight charges up to Bangalore Airport may be sent along with the offer.



d) SPECIFICATIONS:

Items/Equipment offered should strictly conform to our specifications. Deviation, if any should be clearly indicated by the Supplier in their quotation. The Supplier should also indicate the Make/type No. of the stores offered and provide catalogue(s), Technical literature(s) and sample(s), wherever necessary along with the quotations. Test certificates wherever necessary should be forwarded along with the supplies. Whenever options are called for in our specifications, the Supplier should address all such options. Wherever specifically mentioned by us the Supplier could suggest changes to specifications with appropriate response for the same.

1. Corrections, if any, must be attested. All amounts shall be indicated both in words as well as in figures. Where there is difference between amounts quoted in words and figures, amount quoted in words shall prevail.
2. The Supplier should supply along with the tender, the Banking information for payment or any other purpose
3. A complete set of instruction and operation manual should be supplied at the time of installation.
4. Final performance should be guaranteed at the site.



TERMS AND CONDITIONS OF CONTRACT

1. DEFINITIONS:

- a). The terms 'Purchaser' shall mean the Director, Indian Institute of Astrophysics, Bangalore-560 034.
- b). The term 'Supplier' shall mean, the person, firm or company with whom or with which the order for the supply of Items/Equipment is placed.
- c). The terms 'Purchase Order' shall mean the communication signed on behalf of the Purchaser by an officer duly authorized intimating the acceptance on behalf the Purchaser on the terms and conditions mentioned or referred to in the said communications accepting the tender or offer of the supplier for supply of Items/Equipment.

2. PRICES:

The price may please be indicated on unit basis only.

Duty Exemption:

Please note that we may issue "Customs duty Exemption Certificate", if acceptable under the Govt. of India notification No. 51/96 valid till 2011.

3. GUARANTEE AND REPLACEMENT:

- a) The Supplier shall guarantee that the Items/Equipment supplied shall comply fully with the specifications laid down, for material workmanship and performance. The Guarantee should be for a period of one year minimum from the date of supply.



4. **PACKING, FORWARDING AND INSURANCE:**

The Contractor will be held responsible for the stores being sufficiently and properly packed for transport by sea or air, to withstand transit hazards and ensure safe arrival at the destination. The packing and marking of packing shall be done by and at the expenses of the contractor. The Purchaser will not pay separately for transit insurance, all risks in transit being exclusively of the Supplier and the Purchaser shall pay only for such Items/Equipment as are actually received in good condition, in accordance with contract.

5. **TEST CERTIFICATE:**

Wherever required Test Certificate should be sent along with the relevant dispatch documents

6. **ACCEPTANCE OF ITEMS/EQUIPMENT:**

a) The Items/Equipment shall be tendered by the supplier for inspection at such places as may be specified by the purchaser at the suppliers own risk, expenses and cost.

b) It is expressly agreed that the acceptance of Items/Equipment, for is subject to final approval by the Purchaser, whose decision shall be final.

7. **DELIVERY PERIOD:**

Delivery is the essence of the contract. The supplier should adhered to delivery schedule as indicated in the Purchase order.

8. **EXTENTION OF DELIVERY TIME:**

As soon as it is apparent that Supplier dates cannot be adhered to, an application shall be sent by the Supplier to the Purchaser. If failure, on the part of the Supplier to deliver the Items/Equipment in proper time shall have arisen from any cause which the Purchaser may admit as reasonable ground for an extension of the time (and his decision shall be final he may allow such additional time as he considers it to be justified by the circumstances of the case) . In case of Letter of Credit the banking charges for the LOC amendment will be on suppliers account.



9. PAYMENT:

Preference will be given to the supplier whose payment terms is on Site Draft.

10. SECURITY FOR PAYMENT:

Successful Supplier will have to furnish in the form of a Bank Guarantee or any other form as called for by the Purchaser towards any payments before supply of Items/Equipment. In case of payment through Letter of Credit the banking charges out side India and Inside India will be on suppliers account.

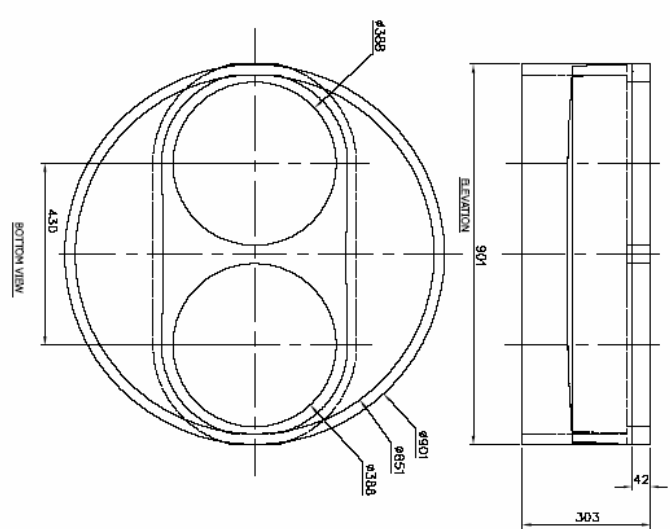
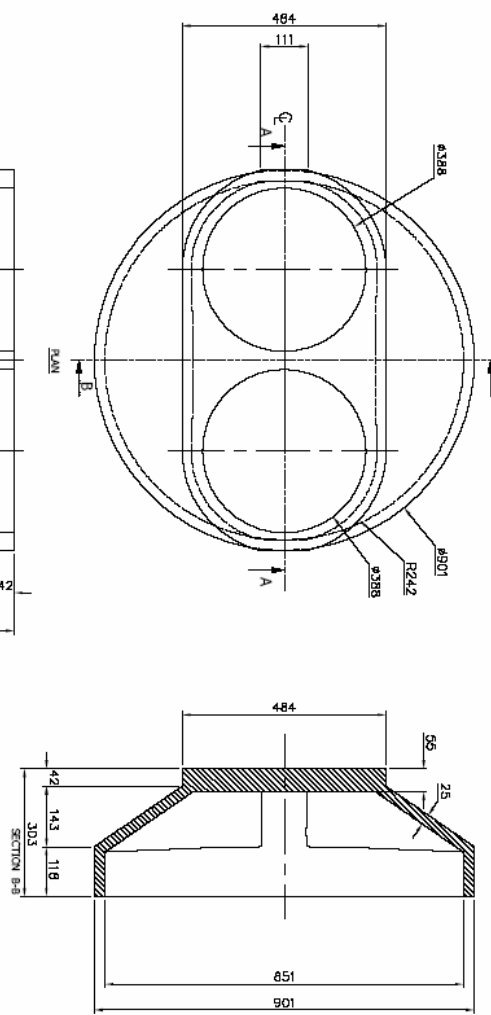

ACAD *.DWG FILE WILL BE MADE AVAILABLE
ON CD/E-MAIL ON REQUEST (IF NEEDED)

- NOTES:
1. ALL DIMENSIONS ARE IN MM.
 2. THIS 2D DRAWING IS GIVEN FOR OVERALL INFORMATION ONLY.
 3. FOR MANUFACTURING THE FORGINGS THE 3D MODEL IN STEP FORMAT IS TO BE USED.
 4. THE FORGING OFFERED UNDER THIS RFP SHALL ENCLOSE THE ABOVE ENVELOPE AS A MINIMUM.
 5. FOR COMPLETE SPECIFICATIONS AND OTHER DETAILS REFER THE RFP.

PART NO./ SERIAL NO.		D1		SPACERRAFT ADAPTER		2		TIBAL 4V-GR5		SCALE	
TITLE		DESCRIPTION		QTY		MATERIAL		PROJECTION		NTS	
<p style="text-align: center;">TITANIUM-FORGING FOR-SATELLITE-ADAPTER</p>											
<p style="text-align: center;">GOVT. OF INDIA-MINISTRY OF SCIENCE & TECHNOLOGY INDIAN INSTITUTE OF ASTROPHYSICS BANGALORE - INDIA</p>											
APPROVED		NAME		SIGN		DATE		PROJECT		DIVISION	
DSN./FAB.		NAG/-		NAG/-		15/02/08		UVT		DESIGN	
DRG.CHECK		NAG		JAI		15/02/08		UVT		SCA.RM	
DRAWN		JAI		JAI		15/02/08		UVT		SCA.RM	

FILE NAME :

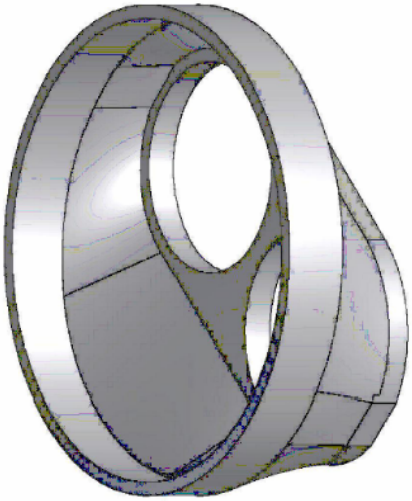
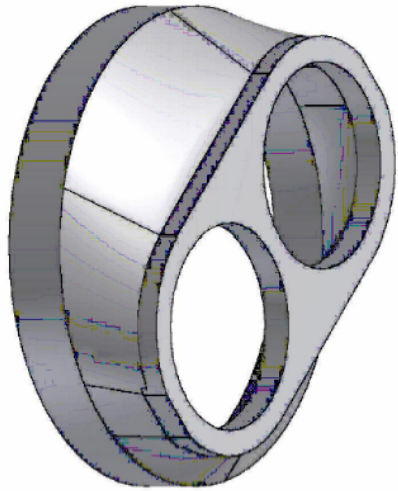

STEP FILE OF THE 3D MODEL WILL BE MADE AVAILABLE
ON CD/E-MAIL ON REQUEST(IF NEEDED)

DT	SPACECRAFT ADAPTER	2	TIBAL-4V-GRS	
DRG NO / SERIAL NO.	DESCRIPTION	QTY	MATL	
TITANIUM-FORGING FOR-SATELLITE-ADAPTER				
<small>DO NOT SCALE THE DRAWING UNLESS OTHERWISE STATED DIMENSIONS ARE IN MM. REMOVE SHARP EDGES.</small>				
APPROVED	NAME	SIGN	DATE	TITLE
DSN /FAB	MAG	—	15/02/08	PROJECT
DRG/CHKD	MAG	—	15/02/08	DESIGN
DRAWN	JAI	—	15/02/08	UVT
 INDIAN INSTITUTE OF SPACE & TECHNOLOGY BANGALORE - INDIA				
GOVT. OF INDIA-MINISTRY OF SCIENCE & TECHNOLOGY INDIAN INSTITUTE OF ASTROPHYSICS BANGALORE - INDIA				
UVT-SCA RM				
				PROJECTION
				SCALE
				NTS
				SHEET
				1 of 1
				1 of 1