

20th August, 2010-08-20

CORIGENDUM – I

Ref: PUBLIC TENDER NOTICE N O:REQ/COMP/027/1011 DATED 27TH JULY 2010, on IIA website for Design, Supply, Installation, Testing and Commissioning of Computer/ Data Centre at IIA, Koramangala, as a turnkey project inclusive of relocation of computer equipments & accessories from existing computer rooms to the proposed datacenter at Ground floor. A concept drawing and specifications are in Annexure II.

EXTENSION OF LAST DATE AS FOLLOWS

- a) Last date for submission of Part I Technical bid and Part II Commercial bid is upto 10th September 2010 at 1500 hours.
- b) Opening of Technical bids (Part I Technical bid) on 10 September 2010 at 1530 hours.

CORRIGENDUM / ADDENDUM FOR THE PUBLISHED RFP OF DATACENTER

Page 2, section 1(b) Tenderer should have completed, in the last 3 financial years (i.e., current year and two previous financial years) at least five similar single work with at least one TIER 3 Data Center built. However the company should have capability of building TIER 4 datacenter. The company should be in similar business for at least past 5 years with minimum orders executed 7 Crores INR every year for the last 3 years. The same should be substantiated with relevant purchase order copies.

Page 10, Section 2.1.2, Please consider the Minimum TR Requirement for the datacenter as 20Tons against 12.5Tons as mentioned in the earlier draft. The Vendor is expected to propose the capacity after analyzing the requirements.

Page 33, Annexure –II, Electrical diagram provided in the RFP shows two input sources of Conventional UPS. The diagram has modified to accommodate one No of modular UPS with only one input and provision for the other input to connect conventional UPS as a redundancy. (Refer to the drawing in this document)

Page 26, Section 10.1, Relative humidity of 40% to 50% may be considered for designing as per the standards instead of 50% mentioned earlier.

ADDENDUM :

The following items of work shall be included in the scope of work.

Conceptual drawing

Schematic drawing of the datacenter provided in the RFP is only for reference. Please also refer to the drawing as given in this document as a guideline only. Detailed layout drawings along with the plan for the user area to be prepared by the bidder and should be part of the proposal. IIA will evaluate for adequacy of design with respect to achieving optimum utilization of space.

LAN rewiring

Rewiring of ground and first floor LAN and shifting of switch rack to the proposed datacenter shall be included.

Comfort AC

One No. of cassette type comfort AC of 2 ton capacity may be included for user area.

Sealed tight for Moisture

All doors/windows/cable opening should be sealed tight for moisture to maintain the positive static pressure.

Vapour/Moisture Barrier.

Vapour/Moisture barrier may be created on all the internal walls, ceilings, flooring, floor/wall joint etc where ever necessary using polyethylene based material/equivalent.

RAMP

In addition to the scope of RFP, a Ramp may be essential to consider at the entrance of the datacenter to move the equipments in and out which was not included in the original document.

CCTV

The scope of work also includes supply, installation, testing and commissioning of a IP based CCTV for datacenter used for effective surveillance and to create a record for post event analysis.

RODENT REPELLANT SYSTEM

Scope shall also include provision for rodent repellent detection system in the Data Center.

AUTOMATIC FLOOR PRESSURISING SYSTEMS (AFPS)

This system should sense the pressure below the Raised floor and it should give command to PAC units to regulate the flow of cold air inside the false floor.

TRANSIENT VOLTAGE SURGE SUPPRESSORS

Transient Voltage Surge Suppressors (TVSS) as per IEEE standards may be included.

BUILDING MANAGEMENT SYSTEM

Building Management System (BMS system) to monitor & manage the Datacenter Infrastructure Equipments which are critical on a 24x7 basis for maximum uptime may be included. Safety procedures as per the NFPA 75 standards/equivalent for the protection of electronic, computer and data processing equipment should be followed.

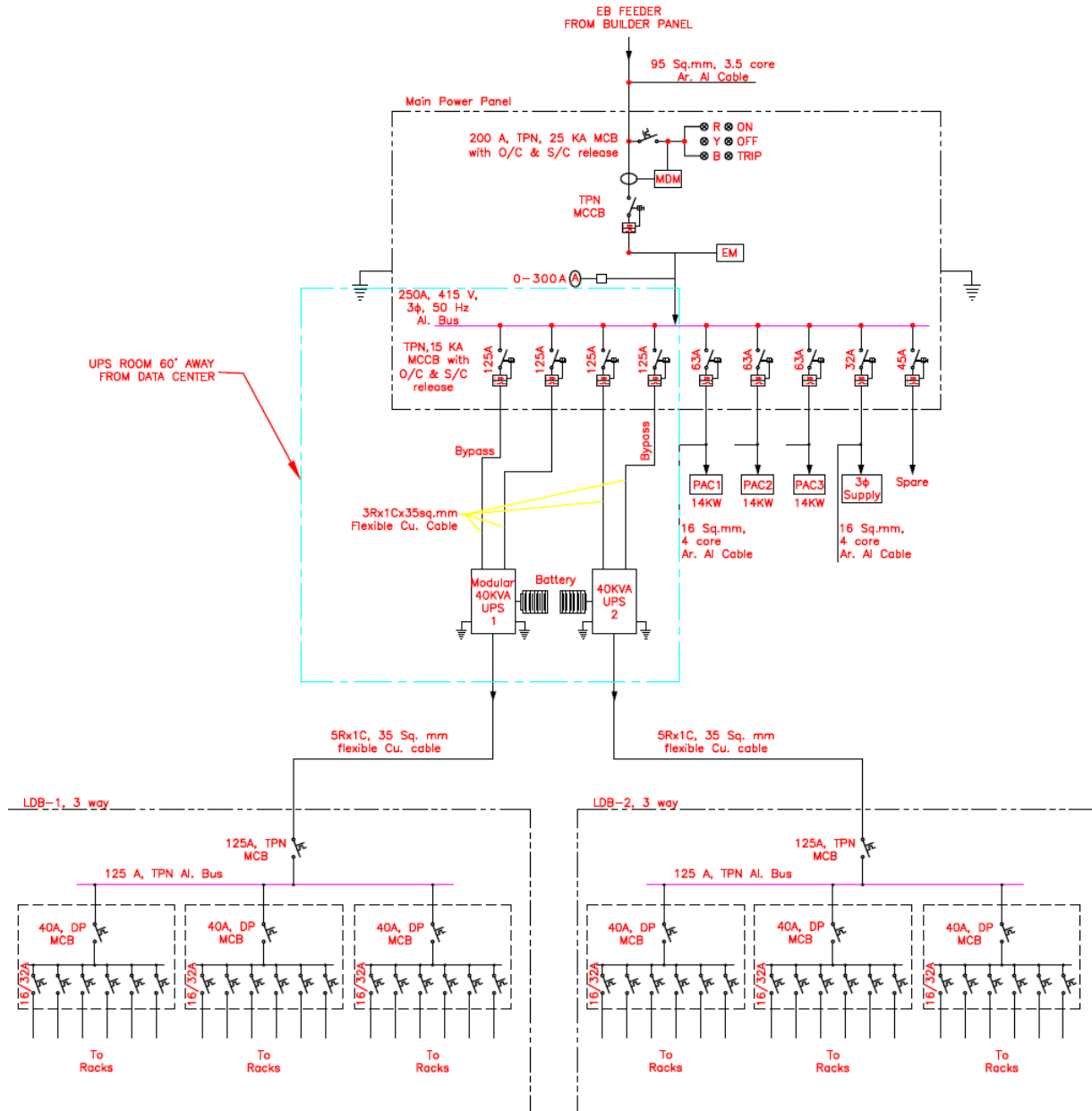

Revised Electrical drawing

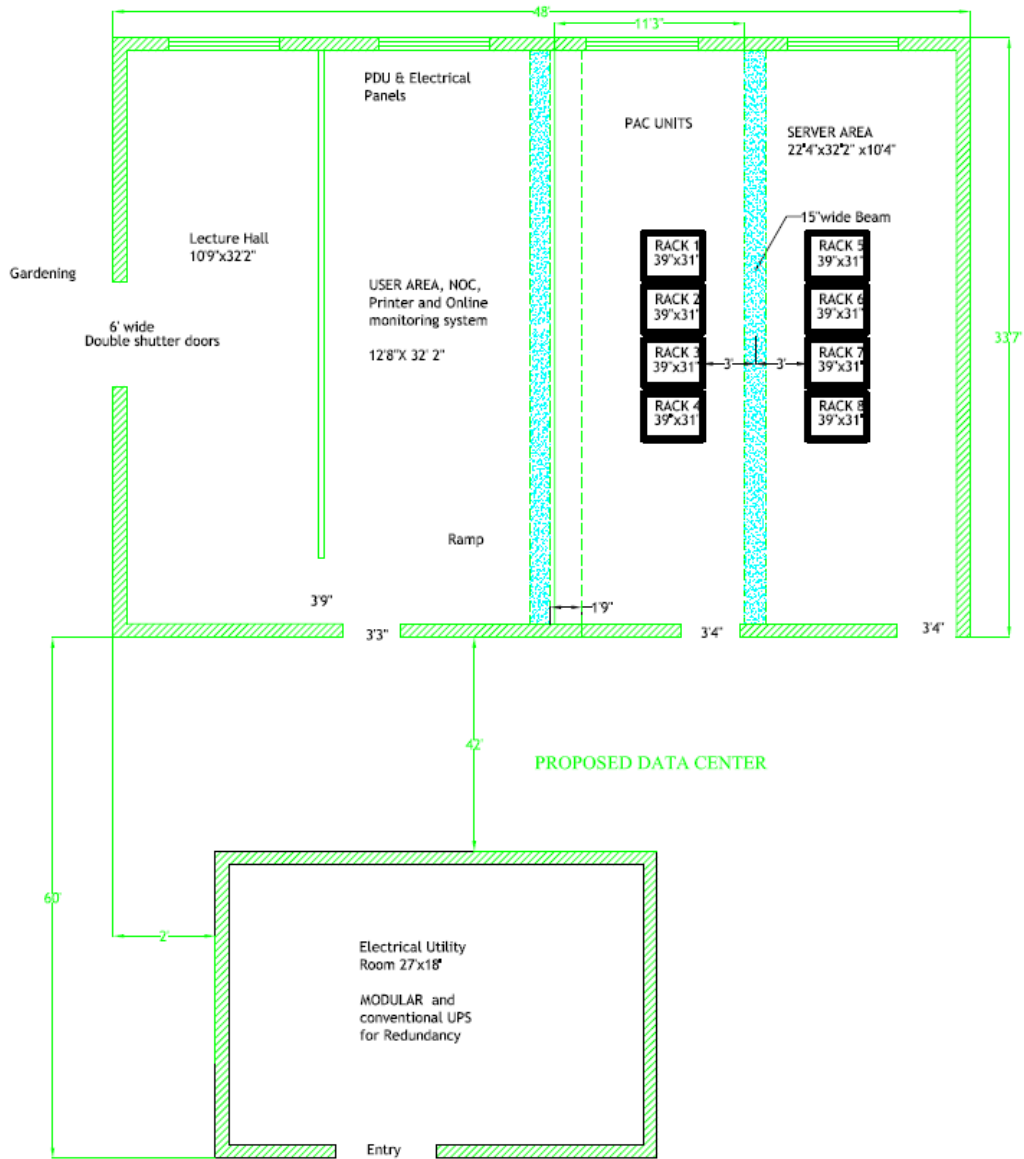

**Administrative Officer
Indian Institute of Astrophysics**