

Request for Proposal (RFP) for the supply of super polished glass substrates

Table of Contents /index:

S.No	Name of the component	Quantity Required
1	Super polished glass substrates	30

Technical specifications of the component

super polished glass substrates

1. Material : ZERODUR
2. Dimesnions : a) Diameter - 50 +/- 0.2mm.
b) Thickness - 8 +/- 0.2mm.
3. Surface quality : One face polished and the other face ground. Polished surface should be free from sleeks/scratches.
4. Surface roughness : Typical average roughness $R_a \leq 0.1\text{nm}$ and typical rms roughness $R_q \leq 0.15\text{ nm}$ over the spatial scales up to 2.15 mm.
5. Surface figure (Polished surface) : ≤ 2 fringes (Regular) with irregularity less than 0.5 fringe
6. Effective aperture of polished surface : 48mm.
7. Homogeneity of surface roughness : Typically, within 5% of specified value of both average and RMS roughness
8. Parallelism with respect to back surface : ≤ 20 microns.
9. Data sheets : a) Certificate of conformance with respect to material type, quality, dimensions and surface quality of polish.
b) Measured roughness data over the spatial scales up to 2.15 mm.

- c) Roughness measurements should be done at 17 locations (approximately) on the sample across the diameter as shown below.

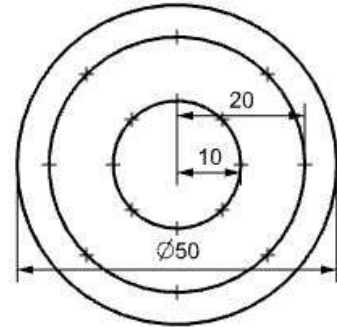

Note:

1. Optical substrates should be packed in ISO-4/5 class clean room compatible containers
2. Polished surfaces should be free from particulate and molecular contamination.
3. Proper handling and storage instructions for the glass substrates to be provided.
4. The calibration details of the instrument used for measurement of the rms roughness should be provided.

Expected deliverables:

As mentioned in "**Table of Contents**" along with conformance certificates for specifications mentioned in "**Technical specifications of the components**" along with all necessary test certificates.

Expected Time Schedule

4 - 6 weeks

For any information/clarifications contact the following

Technical: *venkata@iiap.res.in*

Administrative matters: "*purchase@iiap.res.in*".